

COVID-19:

AUTOANTIBODIES

The impact of COVID antigens on the immune system as sequellae

ABSTRACT

We examine the autoantibodies that can be produced as a result of COVID-19 infections and vaccines and the resulting sequellae which may be possible.

Terrence McGarty

TGL 184 February 2021

Notice

This document represents the personal opinion of the author and is not meant to be in any way the offering of medical advice or otherwise. It represents solely an analysis by the author of certain data which is generally available. The author furthermore makes no representations that the data available in the referenced papers is free from error. The Author also does not represent in any manner or fashion that the documents and information contained herein can be used other than for expressing the opinions of the Author. Any use made and actions resulting directly or otherwise from any of the documents, information, analyses, or data or otherwise is the sole responsibility of the user and The Author expressly takes no liability for any direct or indirect losses, harm, damage or otherwise resulting from the use or reliance upon any of the Author's opinions as herein expressed. There is no representation by The Author, express or otherwise, that the materials contained herein are investment advice, business advice, legal advice, medical advice or in any way should be relied upon by anyone for any purpose. The Author does not provide any financial, investment, medical, legal or similar advice in this document or in its publications on any related Internet sites.

Furthermore, this document contains references to and quotes from papers and documents under the premise of Fair Use in order to present ideas and understandings in context. The Author has attempted to make any and all references to such material separate from those of the author per se and has referenced the source expressly in all cases. These documents are for the dissemination of ideas and have no commercial intent. The Author would appreciate any communications relating to these documents and these should be sent to:

tmcgarty@telmarc.com.

Terrence P. McGarty, Copyright © 2021, all rights reserved. This document is in DRAFT form and is solely for technical review and evaluation and it not intended for any commercial use.

Contents

1	Introduction	5
2	Antibodies and the Immune System.....	8
2.1	Antibodies	8
2.2	B Cells and T Cells.....	11
2.3	Action.....	12
3	Autoantibodies.....	15
3.1	Definition	15
3.2	Generation	18
3.3	T cell Action.....	19
3.4	Effect	19
3.5	NK Cells.....	20
3.6	Production	22
4	COVID-19	25
4.1	Overview	25
4.2	COVID Gene.....	26
4.3	COVID System	27
4.4	Autoantibodies	29
5	Autoantibodies in COVID-19.....	31
5.1	Autoantibodies	33
5.2	Interferon Blocking	35
5.3	Hematological	36
5.4	Myopathy	38
5.5	Pulmonary	38
5.6	Multisystem.....	39
6	Vaccines and Autoimmunity	41
6.1	Autoimmunity	41
6.2	Vaccines	42
6.3	Putative Disorders	43
7	Observations	45
7.1	Mutations.....	45

7.2	Markers.....	45
7.3	Innate vs Adaptive.....	45
7.4	"Mosaic of Autoimmunity"	45
8	References	47
9	Appendix	49
9.1	Microbial Initiators.....	49
9.2	Systemic autoimmune diseases	49
9.3	Organ specific autoimmune diseases:	49
9.4	Antibody Mediated Disease:	50
9.5	T cell mediated.....	50
9.6	Immune Complex mediated:	51
9.7	Summaries.....	51
10	Index	52

1 INTRODUCTION

The Covid-19 virus is becoming a multidimensional threat¹. Unlike previous viral infections this virus presents as follows:

1. High mutational rates as often seen in single stranded mRNA viruses resulting in an ever-changing target for immunization².
2. High multi organ sequella that lead to post infections that are long lasting and result in his morbidity and even residual mortality
3. Autoimmune initiators that result in massive autoimmune sequella with similar effects to multi-organ morbidities

In this report we examine the latter issue, namely the autoimmune responses from autoantibodies. Namely, the antibodies eventually formed as a result of the patient's immune system reacting to the virus may be close to the autoantigens in the patient before infection. This may be therefore one of many processes resulting in the sequellae from the infection³.

As noted in NCI⁴:

An antibody made against substances formed by a person's own body. Autoantibodies can directly destroy cells that have the substances on them or can make it easier for other white blood cells to destroy them. Some autoimmune diseases are caused by autoantibodies.

As Khamsi notes:

... scientists studying COVID are increasingly also highlighting the role of autoantibodies: rogue antibodies that attack either elements of the body's immune defenses or specific proteins in organs such as the heart. In contrast to cytokine storms, which tend to cause systemic, short duration problems, autoantibodies are thought to result in targeted, longer-term damage

It is well known that microbial infections, viral and bacteriological, can produce autoantibodies which in turn can lead to sequella that increase morbidity and mortality. In addition the vaccines that treat such infections have a similar effect. There is also the balancing act that we must

¹ https://www.researchgate.net/publication/345813274_COVID-19_Vaccine_An_Update_and_Primer

² https://www.researchgate.net/publication/348248952_COVID-19_Mutations_and_Infectivity

³ https://www.researchgate.net/publication/347270477_COVID-19_Multi-Organ_Sequellae In this paper we discuss multiple sequellae that have been observed. Our approach in that paper is to look at the innate immune system in contrast to the adaptive. The timing of the sequella may reflect which part of the immune system is causing the problem.

⁴ <https://www.cancer.gov/publications/dictionaries/cancer-terms/def/autoantibody>

reduce the potential for mutants and their resulting threats so the use of vaccines has a possible overall beneficial effect. There is thus a balancing act both medically and socially in dealing with these issues. We do not pose a solution to this balance however it is essential to have a conversation regarding sequella.

We have previously examined sequella resulting from innate system responses including the now classic cytokine storm. These sequella often result during the time of initial infection or proximate to recovery. These sequella can be abrupt and can be quite severe immediately. The second type of sequella is a longer term one resulting from actions of the adaptive system. Namely the productions of autoantibodies that result in the attacking of the cells of the recovering patient. We examine some of these issues herein. It is important to note that autoimmune pathologies take time to be observed and their initial symptoms may be slight but insidious. This means that there must be a careful monitoring process to track these effects.

Thus we can look at the COVID virus as a multipronged threat as shown below.

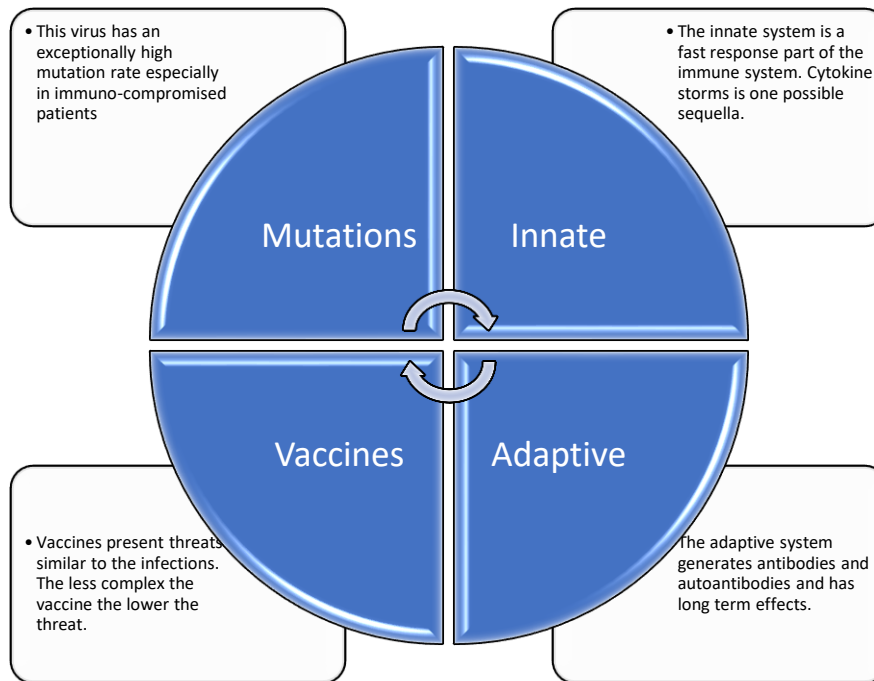

The above paradigm lays out the overall threat matrix from this virus and it presents the needs to be vigilant.

The overall objectives of this report are as follows:

1. Review the basic paradigms of the immune system including both innate and adaptive systems. We have previously looked at NK cells and sequella to COVID-19 but these were generally short term.

2. Examine the basic constructs of autoantibodies and their relationships to autoimmune diseases. Clearly autoantibodies may be readily generated by a variety of microorganisms such as COVID. However the working of these in the process of autoimmunity deserves some review and update.

3. We then briefly review COVID and its mechanism. The major concern we have is that there rate of mutation is high and thus a multiplicity of autoantibodies and result. We then examine a variety of recently recognized autoantibody autoimmune disorders based upon COVID-19. What is critical here is that autoimmune disorders frequently require long lead times and since we have been at this pandemic for just about a year we have a great deal to learn. However it is essential to examine these potentials.

4. We then examine the autoimmune response from vaccines. This is not meant to be some anti-VAX response but a clinical warning to be aware of possible sequella there as well.

2 ANTIBODIES AND THE IMMUNE SYSTEM

It is worth a brief review of how antibodies arise, what they look like and then how they react as part of the immune system. Recent review articles such as that of Bluestone and Anderson have focused on such elements as the T cell response in autoimmune disorders. Autoimmune disorders are highly complex and besides the T cell responses we also have massive autoantibody effects as well. We examine some of these here.

2.1 ANTIBODIES

Let us start with the basic antibody structure focusing on an IgG form. We show this below. It has the long and short arm and the two binding sites. The Ab can bind to the antigen and to the phagocytic cell such as an NK cell. Fundamentally the Ab is a targeting protein that is generated by a complex set of orderings on genes normally in a lymph node.

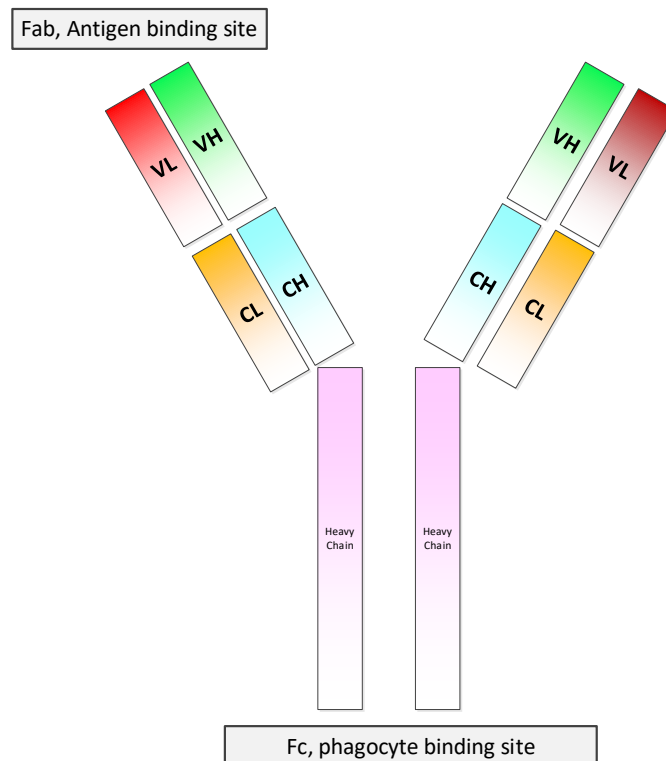

The basic paradigm for the function is shown below for a cell attached Ag and the binding of the Ab thus allowing for a connection of a phagocyte. Identifying the attacked cell as self usually requires the presence of an MHC 1 molecule and inhibitory signalling.

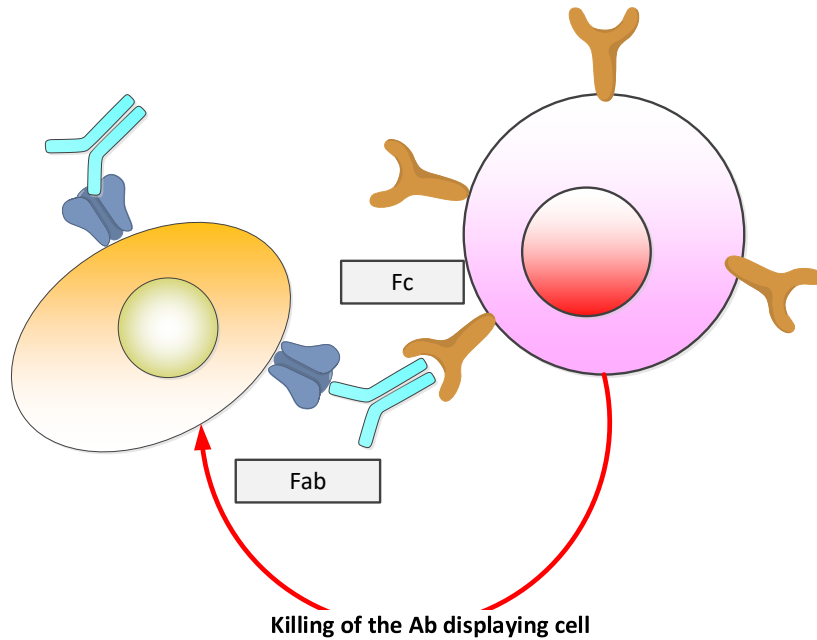

In a similar manner with Abs attached directly to the virion spikes we can use the ability of the NK cells to directly attack and destroy the virions.

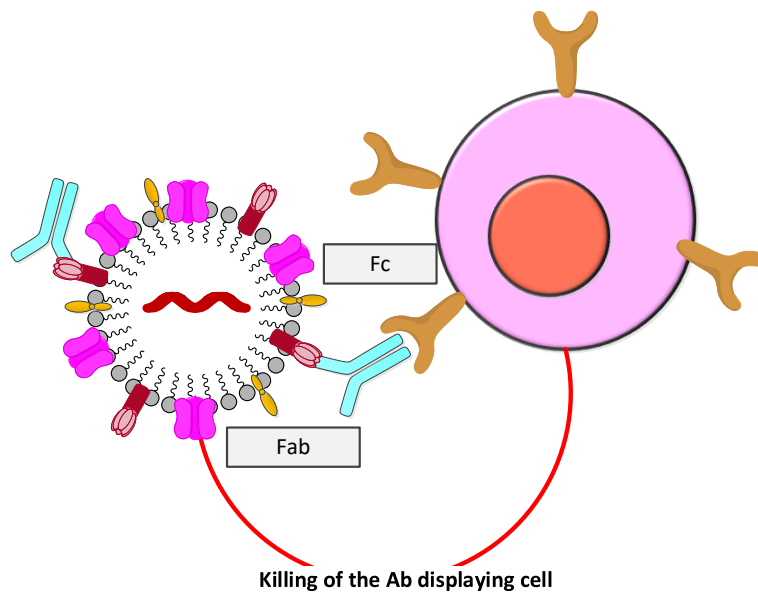

Now the profiles of the Ab genes are shown below. To generate various Abs they genes are selected in a randomized manner and in addition nucleotides may be added or deleted as the random segments are assembled. This quasi random assemblage is then the basis for a substantially large set of Ab.

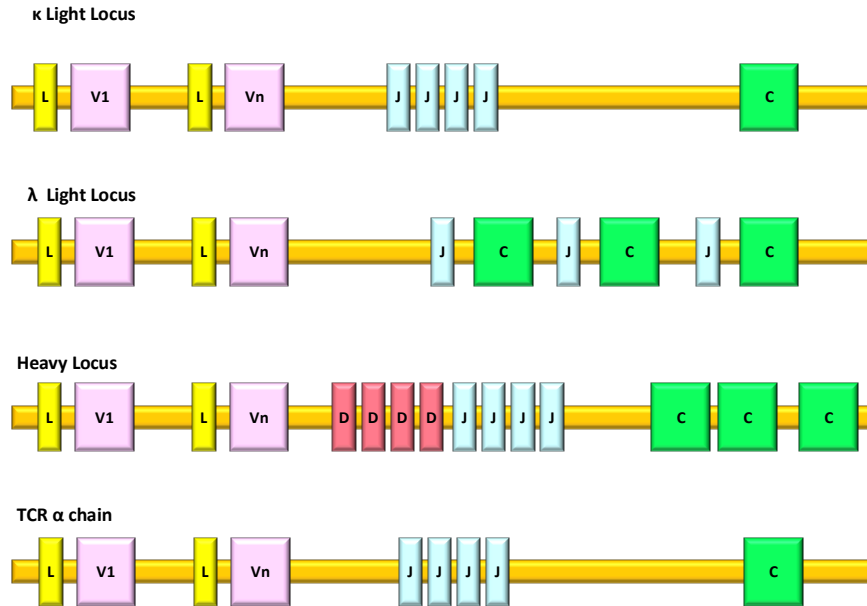

Switch recombination: Molecular mechanism underlying Ig isotype switching in which a rearranged VDJ gene segment in an antibody-producing B cell recombines with a downstream C gene and the intervening C gene or genes are deleted. DNA recombination events in switch recombination are triggered by CD40 and cytokines and involve nucleotide sequences called switch regions located in the introns at the 5' end of each CH locus.

We summarize this process below in the three general steps.

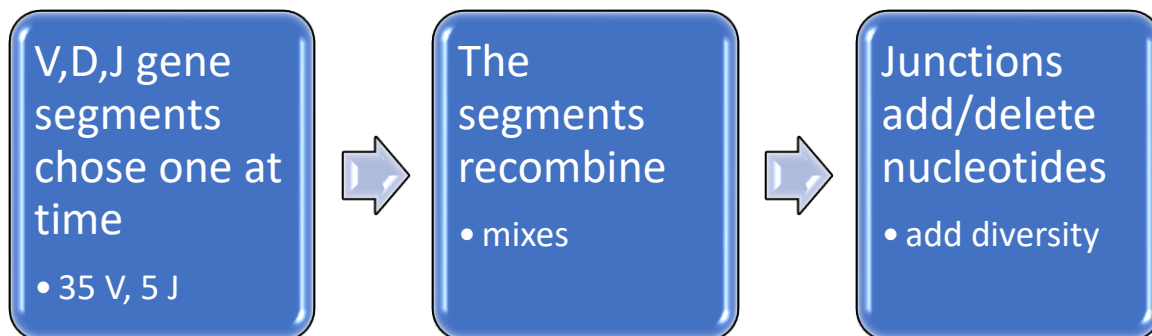

Now clearly some of these randomly generated Ab may match auto antigens, namely proteins on the surface of health cells. Thus it is critical that the immune system can readily recognize self from non self.

2.2 B CELLS AND T CELLS

We now present several key issues to be focused on regarding both B and T cells and their role in autoimmunity. From Chowdhury et al, as modified, we present below the complex of actions of the related cells and the virus.:

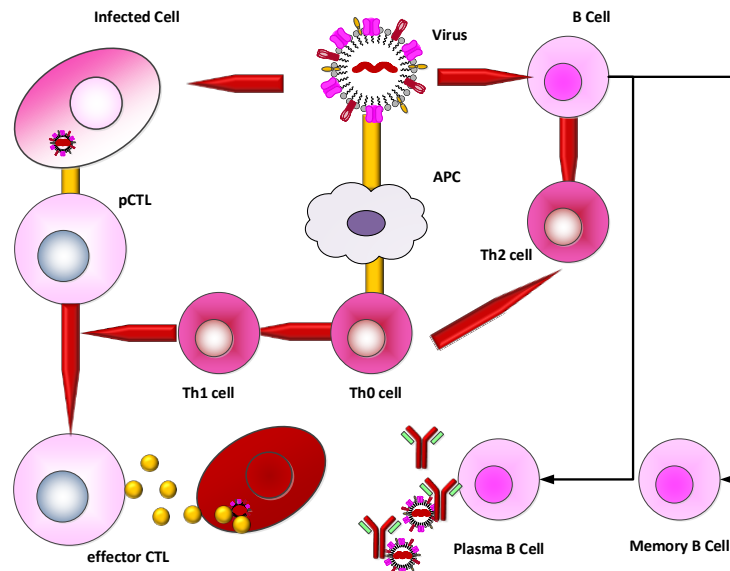

Basically the above demonstrates the ability of the B cells to produce antibodies to coat the free virus on one hand and to eliminate infected cells on the other hand. Continuing from Chowdhury:

However, there is evidence that T cells initiate autoimmune disease as follows:

- 1. Even autoimmune diseases caused by IgG-mediated mechanisms (hypersensitivity types II and III) require T-cell help for affinity maturation to produce pathogenic (disease-causing) antibodies.*
- 2. Transfer of T cells from an animal with autoimmune disease to a healthy animal can transfer disease.*
- 3. Autoimmune diseases are often linked to specific major histocompatibility complex (MHC) genes, which regulate T cells but not B cells.*

The above three observations will be an integral part of our approach and analysis.

2.3 ACTION

We now will examine the steps in which the virus is attacked. Some definitions are worthwhile to be presented first in terms of what we see in such interactions.

Affinity: Strength of the binding between a single binding site of a molecule (e.g., an antibody) and a ligand (e.g., an antigen). The affinity of a molecule X for a ligand Y is represented by the dissociation constant (K_d), which is the concentration of Y that is required to occupy the combining sites of half the X molecules present in a solution. A smaller K_d indicates a stronger or higher-affinity interaction, and a lower concentration of ligand is needed to occupy the sites.

Affinity is a measure of binding strength. The Ab and the Ag are both proteins and the folding of the protein creates negative/positive charged sections which allow for the two proteins to attach and thus begin the process.

Avidity: Overall strength of interaction between two molecules, such as an antibody and antigen. Avidity depends on both the affinity and the valency of interactions. Therefore, the avidity of a pentameric IgM antibody, with 10 antigen-binding sites, for a multivalent antigen may be much greater than the avidity of a dimeric IgG molecule for the same antigen. Avidity can be used to describe the strength of cell-cell interactions, which are mediated by many binding interactions between cell surface molecules.

Avidity deals with then entire molecule binding. Many of the details we are still uncertain of yet we present two examples below of how the Ab and the virus spike Ag react. First the Ab can coat the virion inhibiting the binding, in this case to the ACE2 receptor. Second the Ab may also stop the movement from an infected cell to other cells. This description is the step where the Ab is free to bond and that the bonding inhibits further infection. The strength of the bond is a critical factor. Note also that the spike Ag bonds with the ACE2 receptor. Another approach would be to saturate the ACE2 receptors with monoclonal Ab. But that would create a systemic problem since ACE2 is needed to convert angiotensin from 1 to 2.

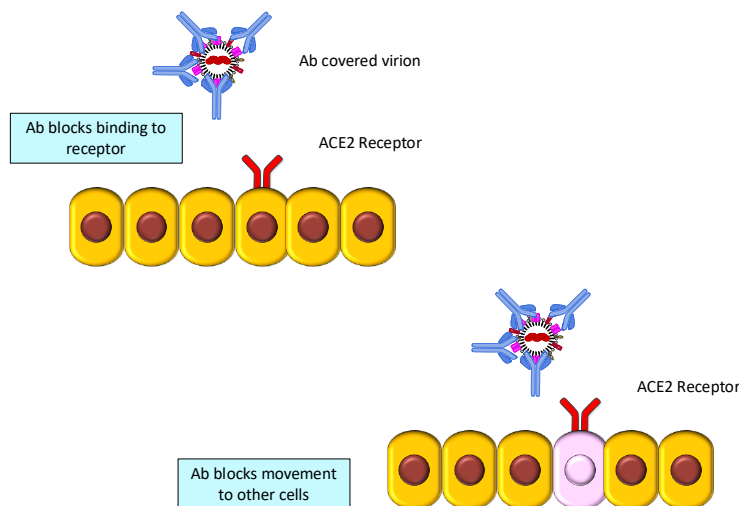

The second example we show below. Here we have an infected cell with the spike being displayed on the surface. In this case the Ab binds to the spike and then a CTL lymphocyte or KK cell binds to the infected cell and releases cytokines to kill the cell. It is this step that we would be concerned about with an autoantibody. Cells have a multiplicity of surface proteins and if the Abs we end up creating become bound to the surface and activate the CTLs we then get a strong immune response on normally healthy cells. Thus an autoimmune disease.

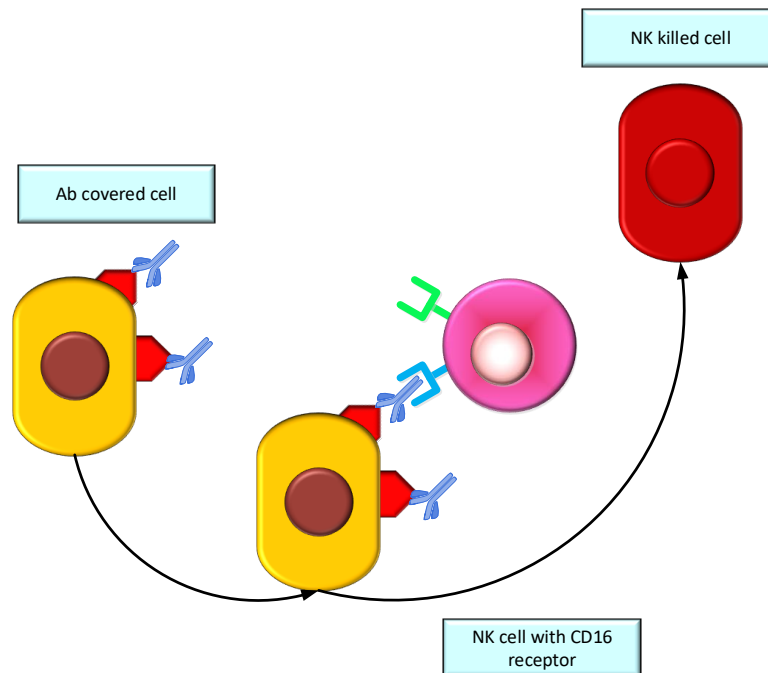

The above is an example of a NK or CTL attack. If the cell is NK we see what Rajalingam has noted:

Natural Killer (NK) cells are the third population of lymphocyte in the mononuclear cell compartment that triggers first-line of defense against viral infection and tumor transformation. Historically, NK cells were thought of as components of innate immunity based on their intrinsic ability to spontaneously kill target cells independent of HLA antigen restriction. However, it is now clear that NK cells are quite sophisticated and use a highly specific and complex target cell recognition receptor system arbitrated via a multitude of inhibitory and activating receptors.

Killer cell immunoglobulin-like receptors (KIR) are the key receptors of human NK cells development and function.

To date, fourteen distinct KIRs have been identified: eight are inhibitory types, and six are activating types.

The number and type of KIR genes present varies substantially between individuals. Inhibitory KIRs recognize distinct motifs of polymorphic HLA class I molecules. Upon engagement of their specific HLA class I ligands, inhibitory KIR dampen NK cell reactivity. In contrast, activating KIRs are believed to stimulate NK cell reactivity when they sense their ligands (unknown). KIR and HLA gene families map to different human chromosomes (19 and 6, respectively), and their independent segregation produces a wide diversity in the number and type of inherited KIR-HLA combinations, likely contributing to overall immune competency. Consistent with this hypothesis, certain combinations of KIR-HLA variants have been correlated with susceptibility to diseases as diverse as autoimmunity, viral infections, and cancer. This review summarizes our emerging understanding of KIR-HLA diversity in human health and disease.

The KIR genes and proteins provide a modicum of self protection in the case of an NK attack. Also it should be noted that NKs may not attack at first, but they can have a delayed attack as the autoantibodies are formed.

3 AUTOANTIBODIES

Autoantibodies are quite common. They are the individual's system attacking itself, via activation by autoantigens. We examine here some of the more common autoantibody issues. Then we briefly examine the work done thus far showing that the more common autoantibodies seem to have little effects upon COVID-morbidity and mortality as de novo incidences.

Autoantibodies are antibodies against self. Normally the human exhibits an immunological tolerance, namely an ability to recognize self while recognizing an antigen. This immunological tolerance to self-antigens, those antigens generating possibly autoantibodies, may be developed in the antibody generating lymphoid organs or in secondary lymphoid organs or in the actual peripheral tissues⁵.

3.1 DEFINITION

We start with a definition of autoantibodies. From Elkon and Casali we have the following discussion:

Antibodies that react with self-molecules occur in healthy individuals and are referred to as natural antibodies or autoantibodies. Natural autoantibodies are mainly IgM, are encoded by unmutated V (D)J genes and display a moderate affinity for self-antigens. They provide a first line of defense against infections, probably serve housekeeping functions and contribute to the homeostasis of the immune system.

By contrast, high-affinity, somatically mutated IgG autoantibodies reflect a pathologic process whereby homeostatic pathways related to cell clearance, antigen-receptor signaling or cell effector functions are disturbed. In some autoimmune disorders, autoantibodies might be present before disease onset, show remarkable specificity and serve as biomarkers providing an opportunity for diagnosis and therapeutic intervention. In organ-specific autoimmune diseases, such as myasthenia gravis or pemphigus, autoantibodies directly bind to and injure target organs.

In systemic autoimmune diseases, autoantibodies react with free molecules, such as phospholipids, as well as cell surface and nucleoprotein antigens, forming pathogenic antigen-antibody (immune) complexes. These autoantibodies injure tissues and organs through engagement of Fc γ R activation of complement as well as internalization and activation of Toll-like receptors. Activation of intracellular Toll-like receptors in plasmacytoid dendritic cells leads to the production of type I interferon, whereas engagement of intracellular Toll-like receptors on antigen-presenting cells stimulates cell activation and the production of other inflammatory cytokines. Thus, immune complexes might perpetuate a positive feedback loop amplifying inflammatory responses....

⁵ See Abbas et al, Chapter 9

Autoimmunity can be defined as adaptive immune responses with specificity for self-antigens. Autoantibodies are antibodies directed at normal cellular components, referred to as autoantigens.

Most healthy individuals produce some autoantibodies, although these are usually very low level and low affinity and require sensitive tests for their detection. Higher-affinity auto-antibodies detectable with routine clinical tests are also found in some healthy people, especially women and the elderly. For example, low levels of antinuclear cytoplasmic antibodies (ANCAs) are seen in one-fifth of healthy elderly people. It has been estimated that after random immunoglobulin (Ig) gene recombination, more than half of the emerging B-cell receptors have specificity for self-antigen.

The observation that autoantibodies are present at low levels in many people means that the process can proceed but that its morbidity factor can be delimited. The details are yet to be fully understood. They continue:

The checkpoints in B-cell ontogeny prevent the majority of B cells from producing autoantibodies.

Autoreactive B cells are either deleted or become nonfunctional. In any case, most autoreactive B cells are unable to secrete Ig in the periphery without help from T-helper (TH) cells responding to the same antigen.

Normally our immune system appears to have a variety of checkpoints and delimiters to assure that self attack does not occur. However in the case of autoantibodies there are ways and means for this attack to continue. From Strayer and Saffritz we have the following:

Autoimmune diseases have traditionally been considered to be prototypical immune complex diseases, with immune complexes forming in the circulation or in tissues. Thus, type II (cytotoxic) and type III (immune complex) hypersensitivity reactions explain most autoimmune tissue injury. But of course the story is more complicated. In some autoimmune diseases, for example, T cells sensitized to self-antigens (such as thyroglobulin) cause tissue injury directly (type IV reaction).

In ADCC, antibodies against cell membrane antigens can destroy such antigen-bearing cells. Thus, antibodies to parietal cell H⁺/K⁺-ATPase contribute to development of atrophic gastritis—but not in all patients, as many people have antiparietal cell antibodies but do not develop gastritis. Not all autoantibodies cause disease via cytotoxicity.

In antireceptor antibody diseases, like Graves disease and myasthenia gravis, antibody-bound cells are not killed (however, anti-acetylcholine antibodies may lead to postsynaptic cell membrane damage). Antibodies against insulin receptors in acanthosis nigricans and ataxia telangiectasia cause some patients to develop extremely insulin-resistant diabetes. Type III hypersensitivity reactions (immune complex disease) explain tissue injury in some autoimmune diseases (e.g., SLE). DNA–anti-DNA complexes formed in the circulation (or at local sites) deposit in tissues, induce inflammation, and injure tissues (e.g., vasculitis, glomerulonephritis).

For many autoimmune diseases, clinical manifestations are systemic, with many organs and tissues affected. However, cytotoxic (type II-mediated) autoimmune antibody reactions are mostly organ specific....

Autoantibodies can be detected in normal people, and many do not cause disease. Some can cause disease when given to experimental animals, thus establishing a cause-and-effect relationship. Others may cross the placenta and harm the fetus, also supporting causality. For most autoimmune diseases, however, the inference that autoantibodies or autoreactive T cells cause the pathology is based on the presence of autoantibodies, often with complement components, or T cells in affected tissues.

Autoimmune Diseases May Reflect T- and B-Cell-Mediated Autoreactivity

Though many autoimmune diseases are largely caused by antibodies, others are mediated by T cells alone. Some (e.g., lupus) seem to involve both autoreactive T and B cells. The sometimes surprising therapeutic effectiveness of B-cell depletion (using anti-CD20) has provoked a reevaluation of the relative role of T cells in certain autoimmune diseases, for example multiple sclerosis.

For some autoimmune diseases, target antigens are few, and well defined (e.g., α -gliadin in celiac disease). For others, it has been difficult to incriminate specific antigens, implying that more complex antigenic spectrum.

Immunity Is Usually Depressed in Patients with Autoimmune Diseases

People suffering from systemic autoimmune disorders have reduced immune responses to exogenous antigens (e.g., vaccines, infectious agents), independently of immunosuppressive treatments they may be receiving. It is almost as if an immune system that is preoccupied with responding to self cannot properly defend against infection. This disease-associated immune impairment can be clinically significant.

We have made this observation as a key point in examining mutation issues. Autoimmune patients have a generally suppressed immune system, thus if infected with the virus there will be many generations of mutations allowing for the evolution of aggressive variants. We have further argued that this fact should and must be at the heart of any remediation strategy. They continue:

For the most part, the antibodies in systemic autoimmune disease patients have all of the characteristics of mature, high-affinity immune responses. Antibodies are against multiple epitopes on complex autoantigens, supporting the idea that the original autoantibody response was indeed antigen driven and not due to a fortuitous cross-reaction or aberrant immune regulation.

Studies using stored predisease serum samples have shown that detectable autoantibodies precede disease manifestations for systemic lupus and RA. Thus autoimmunity most likely leads to these illnesses, and autoantibodies are probably not secondary epiphenomena.

As an added view the work by Elkon and Cassali have noted:

Antibodies that react with self-molecules occur in healthy individuals and are referred to as natural antibodies or autoantibodies.

Natural autoantibodies are mainly IgM, are encoded by unmutated V (D)J genes and display a moderate affinity for self-antigens. They provide a first line of defense against infections, probably serve housekeeping functions and contribute to the homeostasis of the immune system.

By contrast, high-affinity, somatically mutated IgG autoantibodies reflect a pathologic process whereby homeostatic pathways related to cell clearance, antigen-receptor signaling or cell effector functions are disturbed. In some autoimmune disorders, autoantibodies might be present before disease onset, show remarkable specificity and serve as biomarkers providing an opportunity for diagnosis and therapeutic intervention.

In organ-specific autoimmune diseases, such as myasthenia gravis or pemphigus, autoantibodies directly bind to and injure target organs. In systemic autoimmune diseases, autoantibodies react with free molecules, such as phospholipids, as well as cell surface and nucleoprotein antigens, forming pathogenic antigen–antibody (immune) complexes.

These autoantibodies injure tissues and organs through engagement of FcγR activation of complement as well as internalization and activation of Toll-like receptors. Activation of intracellular Toll-like receptors in plasmacytoid dendritic cells leads to the production of type I interferon, whereas engagement of intracellular Toll-like receptors on antigen-presenting cells stimulates cell activation and the production of other inflammatory cytokines. Thus, immune complexes might perpetuate a positive feedback loop amplifying inflammatory responses.

The impact of TLR can be significant as drivers of massive immune responses. We have examined this issue previously in the context of COVID-19 and putative cytokine storm responses.

3.2 GENERATION

What causes the creation of autoantibodies? We understand the driving forces in normal Ab creation and as we noted it is a relatively stochastic process of gene reassembly, insertion, and deletions. The driver is some Ag that finds some Ab where there is a match and off it goes. In discussing the generation of autoantibodies, Uyar has noted:

1. Genetic factors: Immunologic tolerance failure is multifactorial and genetic factors are just one of the causes. For example, the relative risk of having autoimmune disease is 5–50 times higher in siblings of affected individuals than in unrelated ones. Multiple genes; mostly MHC predispose to autoimmune disease and genetic predisposition is detected in many autoimmune diseases. For example, individual with HLA-DR4 gene can be suffered from rheumatoid arthritis but not everyone.

2. Environmental factors: Infections can cause the autoimmune diseases by activating self-reactive lymphocytes. The mechanism is like that an infection led to a local immune response

and activation of APCs. Activated APCs secrete co-stimulators - cytokines and stimulate self-reactive T cells which react with self-antigens in the tissue. Some peptide antigens of microbes are similar to self-antigens, so leads to cross-reactions; called as molecular mimicry. For example; the antibodies against *Porphyromonas gingivalis*; a periodontal pathogen were increased before RA onset and had a relation with RA

3.3 T CELL ACTION

T cells are powerful adaptive lymphocytes that if they become CTL, cytotoxic T lymphocytes, they become powerful killers of infected cells⁶. We demonstrate this below in graphic form.

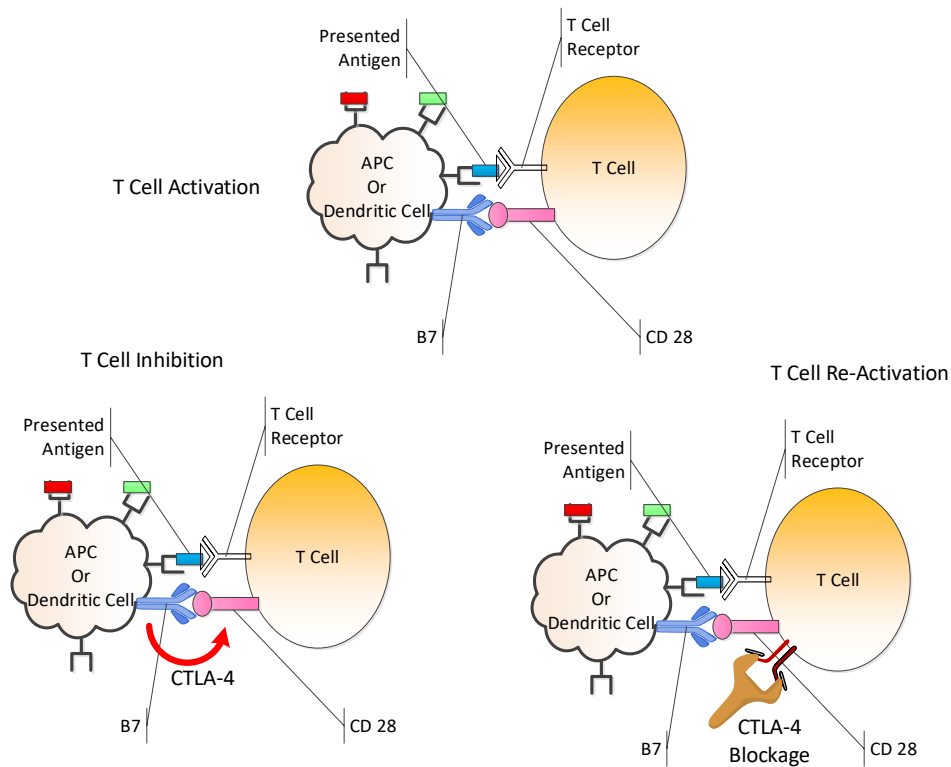

The above shows the self checking capability of CTL using the CTLA-4 check point. We have discussed this at length in a previous work.

3.4 EFFECT

Autoantibodies have been identified in a variety of autoimmune diseases. We detail these in a summary in the Appendix.

Now some of the typical autoantibodies currently tested for are:

⁶ <https://www.researchgate.net/publication/313344954> Immune Set Point Set Points vs Check Points Rev 01

ANA: Antinuclear antibodies. From NCBI⁷:

*Antinuclear antibodies (ANA) refer to an autoantibody directed at material within the nucleus of a cell. ANAs classify typically into two groups, antibodies to nuclear material, and antibodies to DNA and histones. Antibodies to DNA and histones include anti-dsDNA antibodies and anti-histone antibodies. The remaining category includes an additional targeted nuclear antigen. The *first to be identified in this category was the anti-Smith antibody. Others include anti-SSA/Ro, anti-SSB/La, anti-U3-RNP, anticentromere, Scl-70, and Jo-1.*

ANCA: Anti-neutrophil cytoplasmic antibodies. From NCBI⁸:

Anti-neutrophil cytoplasmic antibodies are specific antibodies formed against cytoplasmic granules (antigens) of polymorphonuclear neutrophil granulocytes (PMNs). These autoantibodies are present in ANCA-associated small-vessel vasculitides. The applied use of ANCA lab test, which detects ANCA autoantibodies, is used in the diagnosis of a few vasculitis diseases, mainly pauci-immune small vessel vasculitides granulomatosis with polyangiitis (GPA or Wegener granulomatosis), microscopic polyangiitis (MPA), and to lesser extent eosinophilic granulomatosis with polyangiitis (EGPA or Churg Strauss syndrome) and anti-GBM disease.

APL: Anti phospholipid antibodies. From NCBI⁹:

Antiphospholipid antibodies are autoantibodies that are directed against phospholipid-binding proteins. Antiphospholipid syndrome (APLS) is a multisystemic autoimmune disorder. The hallmark of APLS comprises the presence of persistent antiphospholipid antibodies (APLA) in the setting of arterial and venous thrombus and/or pregnancy loss. The most common sites of venous and arterial thrombosis are the lower limbs and the cerebral arterial circulation, respectively. However, thrombosis can occur in any organ.

3.5 NK CELLS

As Rajalingam noted regarding the impact of NK cells:

NK cells are capable of interacting with a number of cell types through cytokine production and direct cell-cell contact, which have the potential to drive the chronic inflammation. However, accumulating evidence outlined conflicting results of the effect of NK cells in promoting or suppressing inflammatory responses and autoimmune disease development. A protective role for NK cells has been reported in animal models of diabetes, colitis, and experimental autoimmune encephalomyelitis, while in contrast, NK cells have been shown to promote autoimmunity in models of neonatal autoimmune ovarian disease and experimental autoimmune myasthenia gravis. A significant decline in the NK cell population has been reported in the peripheral blood

⁷ <https://www.ncbi.nlm.nih.gov/books/NBK537071/>

⁸ <https://www.ncbi.nlm.nih.gov/books/NBK562339/>

⁹ <https://www.ncbi.nlm.nih.gov/books/NBK430980/>

of patients with a variety of autoimmune disorders, but it is unclear if these alterations are a consequence of ongoing inflammation or are an underlying cause of autoimmunity.

Although the cell surface expression and ligands for activating KIR receptors have not been clearly defined, a growing body of genetic epidemiological data reveals the association of distinct activating KIR in the pathogenesis of autoimmune diseases.

In these models, the activation signals are proposed to prevail over HLA-dependent inhibition that presumably exacerbates NK cell response.

Psoriasis vulgaris is a common inflammatory skin disorder that is strongly associated with KIR2DS1 alone or in combination with HLA-Cw6. A weak association of the activating receptor-ligand pair KIR2DS2:HLA-CAsn80 is observed in diabetes mellitus. Additionally, the unusual genotype of KIR2DS2 in the absence of its inhibitory counterpart KIR2DL2 is found at high frequency in patients with scleroderma (12%) as compared with controls (2%).

Genotypes encoding a dominant activating KIR genotypes (increased number of activating KIR and less inhibitory KIR-HLA combinations) is found to be associated with certain uveitis conditions including birdshot chorioretinopathy (BCR), Vogt-Koyanagi-Harada (VKH) disease, and HLA-B27-associated acute anterior uveitis (AAU) and axial spondyloarthritis.

We may then ask; how do these autoantibodies cause disease. From Elkouss and Cassali we have:

Theoretically, autoantibodies might be neutral or have beneficial or harmful effects. For example, while autoantibodies to thyroglobulin might not make a critical contribution to thyroiditis, long-acting thyroid stimulators (i.e. autoantibodies to the TSH receptor) are responsible for thyrotoxicosis.

Natural autoantibodies might be useful in the removal of cell debris during inflammation, and autoantibodies to inflammatory cytokines might protect against untoward inflammation.

In systemic auto-immune disorders, many autoantibodies seem to be directly injurious following deposition in tissue; they might also amplify inflammation and perpetuate autoantibody production by ferrying self-nucleoproteins into the cell and engaging Toll-like receptors, as discussed previously.

Now the authors focus on the complement system, the key process in the innate response. The complement can be activated by the autoantibodies and the complement can be a powerful and aggressive system attacking the associated cells¹⁰. They continue:

Some autoantibodies engage complement and/or FcγR effector pathways leading to inflammation.

¹⁰ https://www.researchgate.net/publication/314090163_Cancer_Immunotherapy_A_Systems_Approach

*Antigen–antibody complexes are well known to cause **vasculitis and glomerulonephritis**. Activation of complement has been consistently demonstrated in experimental models of immune-complex disease and in kidneys of patients with systemic lupus and lupus nephritis.*

*Other examples of **autoantibody–complement-mediated** injury include the passive transfer model of fetal loss associated with the antiphospholipid syndrome and an unusual form of activation of the alternative complement pathway, induced by autoantibody administration into the transgenic K/BxN mouse as a model of rheumatoid arthritis. Intriguingly, in the latter model, the alternative pathway of complement is activated by pathogenic auto-antibodies directed against the antigen glucose-6-phosphate isomerase.*

Complement activation predominantly causes inflammation by release of the anaphylotoxin C5a, resulting in attraction of neutrophils, and release of proteolytic enzymes and inflammatory cytokines.

3.6 PRODUCTION

As Uyar noted regarding production of autoantibodies:

Production of pathogenic autoantibody can be achieved via the following means.

1. **Somatic hypermutation**: *Each antibody can bind at least 2 (IgG, IgD and IgE isotypes) – maximum 10 epitopes (IgM isotype) of an antigen, which has identical epitopes and are close enough. If the multiple antigen-antibody bind each other, the total strength of the bond is much greater than a single one. This is called the avidity of the interaction. The molar concentration of an antigen needed to occupy half the available antibody molecules in a solution is the dissociation constant (Kd) and used for expression of affinity. The lower the Kd means the higher the affinity.... Mostly point mutations in the genes responsible for variable regions of antibody are detected. They happen in the germinal centers of secondary follicles and AID enzyme that initiate them.*

2. **Class switching**: *The membrane bound IgM and IgD the antigen receptors of naïve B lymphocytes. After stimulation, the antigen specific clone B lymphocytes may proliferate and differentiate into antibody-secreting cells.*

Some of these B cells may secrete IgM, and some others may produce antibodies of other heavy chain classes. The change in Ig isotype production is called heavy chain class switching.

The V regions remains same, specificity of B cells maintains. The exons encoding the constant regions of all antibody classes on chromosome 14, are placed with μ (for IgM) nearest to variable region segments, followed by γ (IgG), α (IgA) and ϵ (IgE). By a successful VDJ rearrangement, first the nearest constant region which is μ is used, resulting in the production of IgM.

Unmutated or minimally mutated recombined VDJ gene sequences encode the multi and monoreactive natural IgM antibodies/autoantibodies. ... After class switch with the same

variable region, these cells can express IgG if the exons encoding the γ constant region; IgA if it is α constant region; and IgE if it is ϵ constant region. T-lymphocytes and other cells release cytokines influence isotype of class switch. Unmutated natural IgM autoantibodies expressed by B1 cells provide the 'templates' for the high-affinity and class-switched IgG and/or IgA autoantibodies which can cause autoimmune diseases. ...

3. **Somatic diversity**: Somatic recombination: **Antibodies are capable of binding a wide variety of antigen, since variable region of antibody molecules forms a flat surface field into different shapes.**

The epitopes or determinants are the parts of antigens that are recognized by antibodies based on sequence (linear determinants) or shape (conformational determinants). Some hidden antigen molecules are exposed after a physicochemical change, called as neodeterminants. Diversity of antibodies is generated by the genetics arrangement of antibody production; unique molecular random generator.

The variable region of an immunoglobulin is formed by both the heavy and the light chain which are carried on different chromosomes. The variable portion of the heavy chain is encoded in separated gene segments of three types, V (variable; the number of gene segments is 65), D (diversity; 27) and J (joining; 6). A complete heavy chain variable region exon is randomly cobbled together by juxtaposing one V, one D and one J segment by a cut and paste process at the DNA level by an enzyme complex containing RAG-proteins (recombination activating gene) which excises intervening DNA, and normal DNA repair proteins directly rejoin the segments. Light chain genes have just V and J segments, not D.

In summary, the diversity of antigen binding is achieved by mostly V genes and their combination with different D and J genes. Different antibodies are produced by four different mechanisms as; randomly combining V-(D)-J segments, randomly combining heavy and light chain, imprecise joining and somatic hypermutation.

Somatic diversity is performed during central B cell intolerance.

4. **Genetic abnormalities**: Some genetic alterations results clinical autoimmune disease but some alterations are influenced by environmental factors. For example; single gen knockout and overexpression lead to clinical autoimmune disease while most of the autoimmune disorders are polygenic.

Three examples of spontaneous or induced genetic alterations lead to clinical diseases.

a. **Abnormal survival of autoreactive lymphocytes**: Mutations in Fas/CD95 causes over expression of the B cell stimulator BLYS; BAFF and the antiapoptotic regulator Bcl-2 which leads the abnormal survival of autoreactive lymphocytes. It causes an autoimmune lymphoproliferative syndrome/Canale Smith syndrome in humans,

b. **Defective removal of apoptotic cells**: A group of proteins as Mer and serum opsonins (e.g., natural IgM antibodies, C1q, serum amyloid P component [SAP] and milk fat globulin epithelial

growth factor-8 [MFGE8]) take role in the removal of apoptotic cells. In Mer deficiency, macrophages take a proinflammatory signal not an anti-inflammatory one for ingestion of apoptotic cells. If there is a defective clearance of apoptotic cells in surface IgM, C1q, SAP and MFGE8, clearance of apoptotic cells leads to postapoptotic necrosis and/or through lack of engagement with specific inhibitory receptors on the phagocyte. In MFG-E8 deficiency, apoptotic cells accumulate in germinal centers and in C1q-deficiency, apoptotic cells accumulate in the kidney. These deficiencies cause lupus-like diseases.

c. Breakdown in the regulation of B cell or T cell activation threshold: If threshold regulators of *cbl-b*, *PD-1* and *Zap-70* and the *SLAM* cluster in T cells, and *Lyn* and *FcγRIIb* in B cells change genetically, failure of peripheral immune system could happens. If lymphocytes are more easily activated, they produce more auto-antibodies as in systemic lupus. Mutations of *Zap-70* lead to production of RFs as in rheumatoid arthritis. *PD-1*-deficiency causes lupus in C57BL/6 and myocarditis in BALB/c. There is some signature autoantibodies cause autoimmune diseases as anti-endomysial antibodies (EMA), anti-gliadin antibodies (AGA). ...

The intracellular Toll-like receptor is activated by nucleic acid which leads to production of interferon and activation of immune system. The protein antigen stimulates T cells, probably are responsible for the specificity of the immune response. These are called Toll hypothesis.

4 COVID-19

We present a brief summary of the COVID-19 corona virus which allegedly originated in some manner from Wuhan, China¹¹. The actual provenance of the virus is yet to be adequately determined. The virus has a very high level of transmissibility, virulence, and mutability. In a short period it has aggressively spread globally and strangely appears to have had minimal impact in China, its source of origin.

4.1 OVERVIEW

The figure below is a graphic example of the corona virus in generic terms. It is a single stranded positive RNA virus with a well-defined spike protein on the surface. The spike protein is a putative target for immunization efforts.

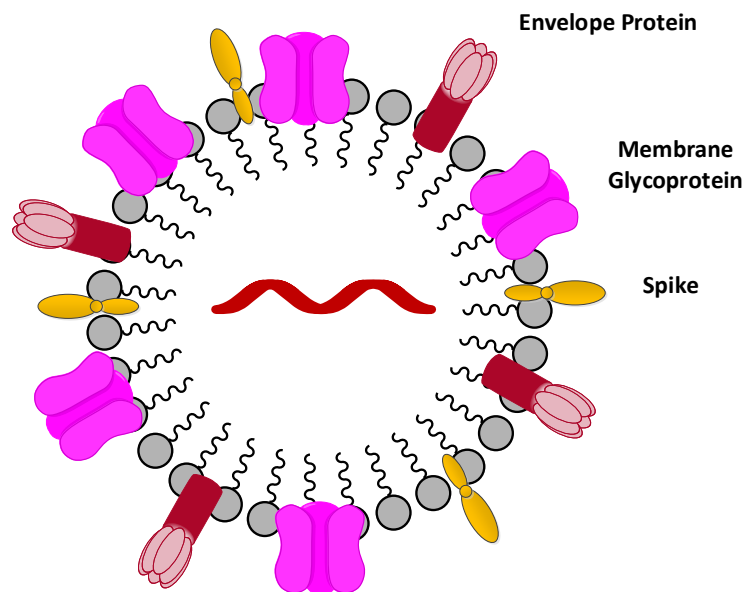

We now consider some detail as regards to this virus. As Artika et al note:

The schematic diagram of coronavirus life cycle.

*The coronavirus infection is initiated by the **binding of the virus particles to the cellular receptors** leading to viral entry followed by the viral and host cellular membrane fusion.*

*After the membrane fusion event, the **viral RNA is uncoated in the host cells cytoplasm.***

¹¹ In March 2020 we prepared a preliminary report on the virus discussing what was known to that data and examining the possible pandemic dynamics. In February 4, 2020 we declared this a pandemic despite the WHO and CDC delaying any prophylactic actions, the delay thus resulting in the current global pandemic, <https://www.telmarc.com/Documents/White%20Papers/173Corona.pdf>

The **ORF1a and ORF1ab** are translated to produce *pp1a* and *pp1ab*, which are subsequently processed by the **proteases encoded by ORF1a** to produce 16 non-structural proteins (*nsps*) which form the **RNA replicase–transcriptase complex (RTC)**.

This complex localizes to modified intracellular membranes which are derived from the rough endoplasmic reticulum (ER) in the perinuclear region, and it drives the generation of negative-sense RNAs ((-) RNAs) through both replication and transcription.

During replication, the **full-length (-)RNA copies of the genome are synthesized** and used as templates for the production of **full-length (β)RNA genomes**.

During transcription, a subset of 7–9 subgenomic RNAs, including those encoding all structural proteins, is produced through discontinuous transcription. In this process, subgenomic (-)RNAs are synthesized by combining varying lengths of the 30end of the genome with the 50 leader sequence necessary for translation.

These subgenomic (-)RNAs are then transcribed into subgenomic (β)mRNAs.

The **subgenomic mRNAs are then translated**.

The generated structural proteins are assembled into the ribonucleocapsid and viral envelope at the ER–Golgi intermediate compartment (ERGIC),

followed by release of the newly produced coronavirus particle from the infected cell

4.2 COVID GENE

Various authors have discussed the general structure of a corona virus gene structure and we present this below. It is a positive single stranded mRNA virus and the mRNA has a form as shown below. It is approximately 30,000 nucleotides in length and the spike protein is approximately 3,000 nucleotides in length. As with most corona viruses it contains in the mRNA, via the non-structural proteins, the ability to reconstruct itself many times over by generating the structural genes and implanting a new copy of the mRNA.

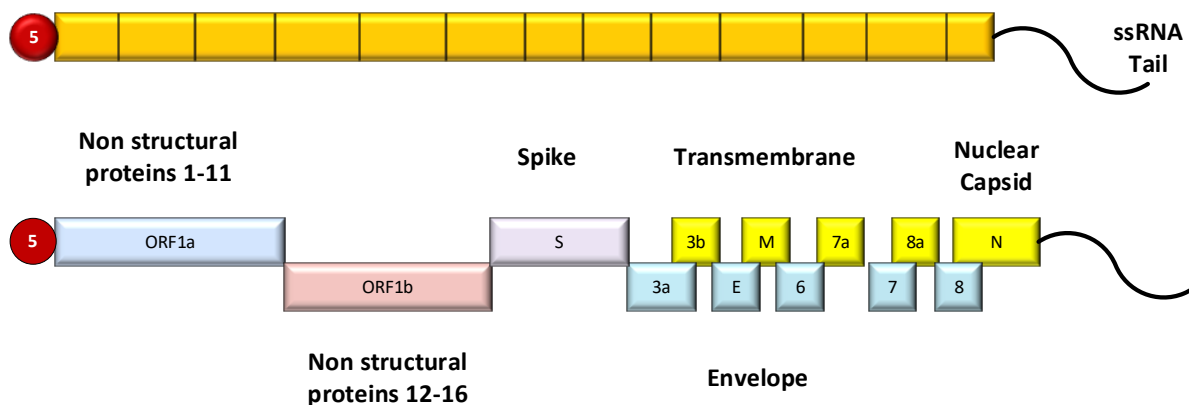

The nonstructural proteins, NSP, for the replicase transcriptase complex. There are four structure proteins:

1. S is the spike forming protein, of which we shall speak of later in detail
2. E is the envelope protein for the new virion
3. M is the membrane protein for the new virion
4. N is the nucleocapsid protein for the new virion

Overall, we now have the two sets; those allowing for self-reproduction and those relating to construction of the new virion.

The following is the detail of the spike gene which we shall discuss later.

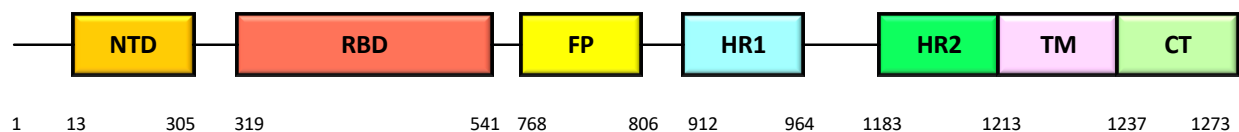

When examining these proteins we must note that the numbers above are those of the nucleic acids whereas the nucleotides are three times the number. Thus the 1273 nucleic acids represent almost 3900 nucleotides. Mutations in any of these nucleotides can result in a mutation of the nucleic acids and thus the protein conformation.

4.3 COVID SYSTEM

We depict the process below for the entry and reproduction of the virion. This process starts with the attachment and entry of the virion and ultimately the release of a collection of new virions until the cell is depleted and dies.

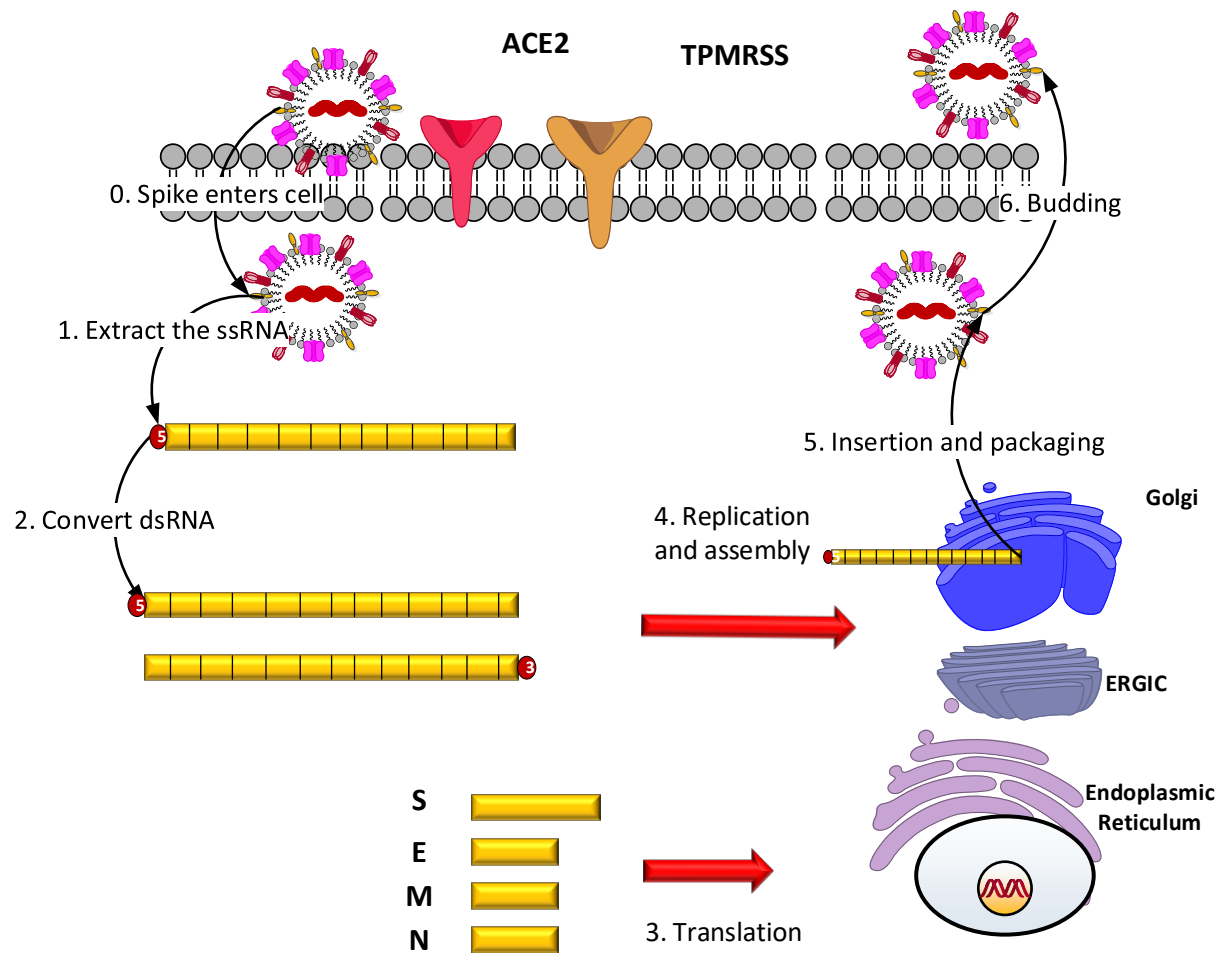

We can summarize the steps as shown above.

1. The virion spike protein attaches to the ACE2 receptor protein. As we will note later this means that there is a selective capability in this specific spike protein. As we shall note from the literature later, strangely this receptor is weak in Chinese individuals and is a strong bond in Europeans and most other ethnicities.
2. The virion then enters the cell and disassembles. The ss mRNA is extracted
3. The structure RNA sequences are then translated in the inter ER/Golgi space into the constituent proteins.
4. The ss mRNA is completed to form a complete ds mRNA which will be used to generate multiple ss mRNAs to be inserted in other new virions. This may be a point for possible mutant changes.
5. The multiple ss mRNAs and the structural proteins are assembled in the Golgi apparatus and extracted.
6. The final result is a repackaged virion which is budded outwards.

These steps are very general and there are as of yet many holes as to exactly how all this is accomplished. Yet for our purposes the processes lay out the locations of the possible mutation sites.

4.4 AUTOANTIBODIES

Having presented the COVID virus we can address the autoantibodies in this context specifically. As Pascolini et al note measurements for common autoantibodies as we have discussed previously:

1. ANA: In our single-center study, 45.4% (15 of 33) of patients with COVID-19 had reactivity to at least one autoantibody. Specifically, 33.3% (11 patients) of the patients had ANA reactivity, characterized in one patient by anti-histone antibodies on specific ENAs. A recent study from China²² including 21 patients documented a slightly higher prevalence of ANA positivity (50% vs. 33%). However, we examined ANA positivity by indirect immunofluorescence, whereas that study examined reactivity by ANA immunoblot. Furthermore, the studies enrolled 2 different subsets of patients with COVID-19. ...

... It is of interest that the prevalence of auto-antibodies was higher in critical cases of COVID-19 than in less severe cases in both of these studies. The nucleolar pattern of ANAs is often associated with the interstitial pneumonia that characterizes the clinical course of systemic sclerosis. Samples from four of our patients showed nucleolar staining of ANAs, and these patients also had a radiological definitive diagnosis of interstitial pneumonia, but none had reactivity against Scl-7. Such reactivity usually represents the target antigen in diffuse systemic sclerosis.

2. APL: We observed an overall frequency of APLs of > 21% (7 cases), which is at least 2-fold more than that reported by Harzallah and colleagues in a series of 56 patients with COVID-19. Furthermore, the presence of APLs in this study was significantly associated with poor prognosis. Unlike Tang et al.,¹⁶ who identified coagulopathy as an independent negative prognostic factor, we did not observe any difference in these parameters among patients with poor prognosis and those with good prognosis. This difference could be due, at least in part, to the different selection criteria and is also likely affected by the lower number of cases in our series (183 vs. 33). However, we did observe a significant association between autoreactivities and poor prognosis in our series; all but one of our severely ill patients had at least one autoreactivity.

*The majority of post-infectious APLs differ immunochemically from those seen in patients with autoimmune disease. Infection-induced APLs have been traditionally regarded as transient phenomena and are generally **not associated with clinical features of anti-phospholipid syndrome (APS)**. However, this classification has been challenged by reports describing thrombotic events following infection and in particular by the association of the most aggressive form of APS, catastrophic APS, with infectious triggers. None of our patients experienced thrombotic complications, which suggests that our findings are compatible with an epiphenomenon of infection-induced immune dysregulation. Therefore, our findings should be*

evaluated as part of the complex viral-host interaction rather than an independent autoimmune phenomenon.

3. ANCA: It is of particular interest that none of our patients had ANCA reactivity. *ANCAs are reactive against multiple antigens in the cytoplasmic and perinuclear regions in neutrophils and monocytes. The most prevalent ANCAs in ANCA-associated vasculitis target myeloperoxidase and proteinase 3 and are strongly associated with small vessel vasculitis. It is believed that, in genetically predisposed patients, the first neutrophil immune response may lead to antigen presentation and chronic immune dysregulation in small vessel vasculitis. However, the immunopathology of vasculitis is still unclear.*

Several models have suggested that T-lymphocytes may play a leading role in the loss of tolerance and development of autoimmunity. Additionally, some studies have evaluated the cytokine profile in these patients, showing that the cytokines IL-6, IL-10, TNF- α , IFN- γ , and IL-17A are increased in patients with adeno-associated virus infection. The lack of expression of these markers in our study may be because of the small number of cases. Additionally, our serological tests may have been performed too early to detect antigen presentation and the subsequent rise in autoreactivity titers. By contrast, it is possible that the initial viral immunosuppression may decrease the first neutrophil response and inhibit ANCA production.

Thus from this above presentation we see a significant amount of autoimmune prevalence and impact. We shall thus focus on these COVID-19 autoantibodies.

5 AUTOANTIBODIES IN COVID-19

Autoantibodies have been found to have a significant effect on the aggressiveness and mortality resulting from COVID-19 infection. As Khamsi noted:

*SARS-CoV-2 might cause the body to generate autoantibodies that attack its own tissues. Some of the infected individuals had **autoantibodies** against proteins in their **blood vessels, heart and brain**. This was particularly intriguing because many of the symptoms seen in the pandemic are linked to these organs. It's unclear whether COVID-19 infection caused the body to start making these autoantibodies or whether infected people had them already. Iwasaki says they are hoping to study other cases to establish whether there is a causal link; that would require obtaining more blood samples from before people become infected*

We have previously examined such sequella as myocarditis. Our examination was predicated on cytokine storm type responses but there now appears to be a putative basis for the effect of autoantibodies. We know that autoantibodies in other cases cause autoimmune disorders with effects similar to what we see in COVID-19. However the exact nature is not fully understood.

As Wang et al have noted:

1. *COVID-19 patients have widespread autoantibody reactivity against extracellular antigens*
2. *Autoantibodies in COVID-19 patients target a wide range of immune-related proteins*
3. *Autoantibodies targeting cytokines/chemokines are associated with distinct virological and immunological characteristics in COVID-19*
4. *Autoantibodies targeting immune cell surface proteins are associated with specific changes in blood leukocyte composition*
5. *Immune-targeting autoantibodies exacerbate disease severity in a mouse model of SARS-CoV-2 infection*
6. *Autoantibodies targeting tissue-associated antigens correlate with disease severity and clinical characteristics in COVID-19 patients*

They conclude:

The surprising extent of autoantibody reactivities seen in patients with COVID-19 suggests humoral immunopathology is an intrinsic aspect of disease pathogenesis. Screening patient samples with the REAP platform, we identified and validated numerous protein targets involved in a wide range of immunological functions. These autoantibodies had potent functional activities and could be directly correlated with various virological, immunological, and clinical parameters in vivo within COVID-19 patient samples.

Furthermore, murine surrogates of these autoantibodies led to increased disease severity in a mouse model of SARS-CoV-2 infection. Altogether, these results provide additional evidence that autoantibodies are capable of altering the course of COVID-19 by perturbing the immune response to SARS-CoV-2 and causing direct tissue injury...

The diversity of autoantibody responses in COVID-19 patients also underscores the importance of high-throughput and unbiased proteome-scale surveys for autoantibody targets.

By perturbing biological pathways, autoantibody reactivities are somewhat analogous to genetic mutations³⁵ and can uncover unexpected pathways in disease pathophysiology. For instance, beyond validating the biologically-compelling example of anti-IFN-I antibodies in COVID-19, our studies implicated numerous other immune pathways targeted by autoantibodies in COVID-19 that were not previously associated with the disease.

In addition to immune-targeting autoantibodies, we also detected antibodies against various tissue-associated antigens. These autoantibodies were correlated with inflammatory clinical markers like ferritin, CRP, and lactate in COVID-19 patients, and these correlations became more extreme with worsening disease progression.

Intriguingly, many tissue autoantibodies were present across the diverse physiological compartments frequently implicated during post-COVID syndrome (PCS).

Whether the specific autoantibodies identified here play a role in the establishment of PCS, and whether they persist beyond the acute phase of COVID-19, deserves further investigation given the persistent and growing affected patient population. In summary, our analyses delineated an expansive autoantibody landscape in COVID-19 patients and identified distinct autoantibodies that exerted striking immunological and clinical outcomes.

These results implicate previously underappreciated immunological pathways in the etiology of COVID-19 and suggest novel therapeutic paradigms centered around modulating these pathways, as well as attenuating the autoantibodies themselves.

Finally, our findings provide a strong rationale for a wider investigation of autoantibodies in infectious disease pathogenesis

Now regarding COVID-19, Lerma et al have examined the incidence of these Ab and have summarized¹²:

- i. *Autoantibodies against nuclear antigens are detectable in 25% of patients hospitalized with acute COVID-19.*
- ii. *Anti-nuclear antigen antibodies were weakly reactive and most often directed to single antigens.*
- iii. *Vasculitis-associated autoantibodies were not detected in specimens from patients with acute COVID-19.*
- iv. *Anti-phospholipid antibodies were infrequently detected in patients with acute COVID-19.*

Moreover for each they note:

¹² <https://www.sciencedirect.com/science/article/pii/S258990902030040X?via%3Dihub>

Exuberant immune responses are a hallmark of COVID-19, but the mechanisms leading to immune-mediated damage are unclear. In the present study, we evaluated antibodies to nuclear and other autoantigens in specimens from hospitalized patients with acute COVID-19. ...

Overall, we found that 30% of patients had detectable antibodies to nuclear or phospholipid antigens. Among patients without pre-existing immunologically-mediated disorders, the overall frequency of autoantibodies was 26%. Autoantibody positive patients were more likely to have severe disease requiring care in the ICU and higher levels of anti-SARS-CoV-2 antibodies, but did not have elevated inflammatory markers or total immunoglobulin levels compared to autoantibody negative patients. Longer term follow-up could reveal whether inflammatory markers or levels of immunoglobulin classes or IgG subclasses are altered after COVID-19 and confer susceptibility to chronic infection or inflammation.

Thus the presence of the more common autoantibodies does have some effect albeit most likely from pre-existing condition.

Of patients with any immunoreactivity, 84% had antibodies to nuclear antigens. Thus, in our cohort we did not find any patients who developed strongly reactive antinuclear antibodies in response to acute SARS-CoV-2 infection.

Other acute infections have been associated with detectable ANA that were not indicative of subsequent autoimmune disease, but rather reflected transient autoreactive B and plasma cell activation ...

Although antiphospholipid syndrome is an emerging concern in COVID-19, we did not find evidence of a high prevalence of antiphospholipid antibodies in our cohort...These transient antiphospholipid antibodies are not clearly pathogenic, and diagnosis of antiphospholipid syndrome requires antibody detection over time. ...

5.1 AUTOANTIBODIES

We have discussed the classic autoantibodies. The question some have asked is; does COVID-19 cause an increase in the more common autoantibodies and if so which ones and how much of an increase? As Sacchi et al have noted:

Autoantibodies	All patients (40)		Healthy subjects (40)	
	Pos	Neg	Pos	Neg
ANA	23 (57.50%)	17(42.50%)	05 (12.50%)	35 (87.50%)
Anti-Cardiolipin	05 (12.50%)	35 (87.50%)	05 (12.50%)	35 (87.50%)
Anti β2-Glycoprotein	02 (5%)	38 (95%)	01 (2.50%)	39 (97.50%)
ENA	01 (2.5%)	39(97.50%)	00 (0%)	40(100%)
Anti-PR3	01 (2.5%)	39(97.50%)	00 (0%)	40(100%)
Anti-MPO	00 (0%)	40(100%)	00 (0%)	40(100%)
ANCA	10(25%)	30 (75%)	01 (2.50%)	39 (97.50%)
ASCA IgA	10(25%)	30 (75%)	01 (2.50%)	39 (97.50%)
ASCA IgG	07(17.5%)	33 (82.50%)	01 (2.50%)	39 (97.40%)

The authors continue noting:

ANA, ANCA, and ASCA are not the only antibodies described in literature to be found in patients with COVID-19. Recently, Zhang and colleagues have reported 3 patients affected by COVID-19 who developed cerebral thrombi. These patients had coagulopathy, thrombocytopenia, anti-Cardiolipin IgA, and anti- β 2-Glycoprotein IgA and IgG antibodies.

Usually, the presence of antiphospholipid antibodies is fundamental for the diagnosis of the antiphospholipid syndrome. However, these antibodies can also be detected transiently in patients with critical disease and different infections.²⁸ In another study, other 5 patients with COVID-19 were described to be positive for the same autoantibodies.

In this work, the authors did not clearly explain whether the increased rate of arterial thrombotic events in these patients was caused by the presence of the antibodies.²⁹ We also detected antiphospholipid antibodies in our cohort, although at a low rate. In details, we found that only 5 patients (12.50%) were positive for anti-Cardiolipin and 2 (5%) for anti- β 2-Glycoprotein.

However, there were no significative differences compared with the healthy subjects. According to literature and our data, we could infer that the increase of thromboembolic events that normally occurs in patients with COVID-19 might not be influenced by the presence of antiphospholipid antibodies, but could be also due to other factors.

The results obtained in this study firmly sustained that COVID-19 is associated with autoimmunity, in particular ANA, ASCA, and ANCA antibodies development. To support our findings, it has to be mentioned that 1 of our 40 patients with COVID-19 had a peculiar clinical outcome. At the beginning of his hospitalization, after autoantibodies investigations, his results were negative. However, his clinical condition was highly severe, he had high critical pulmonary and renal disfunctions, and after 1 month of hospitalization, there were no improvements. Therefore, it was decided to repeat the autoimmune analyses.

During this second evaluation, we detected a strong ANA positivity (pattern cytoplasmic 1:160, centriole 1:320, and granular 1:160) and the myositis blot was positive for M2beta and Ku antigens.³⁰ Moreover, another case of onset of autoimmune diseases (Systemic Lupus Erythematosus) following a COVID-19 infection has recently been described in the literature

5.2 INTERFERON BLOCKING

The immune system has a variety of means to attack and eliminate viral invaders. Interferons, IFN, and one of the many approaches to such elimination. IFN are cytokines that can block viral reproduction. There are also interferon regulatory factors, IRF, which are transcription factors that assist and activate antiviral genes in a cell. IRF3 is one which is activated by TLR, toll like receptors, that in turn can deactivate replication.

The question we examine here is; is the damage primary or secondary? Namely if we accept the impact of autoantibodies resulting from COVID-19, do we see them attacking or interfering with the cells directly or is this the result of a secondary interference with the immune system elements? We examine some of the recent efforts here.

From Beck and Aksentijevich we show this process below (as modified):

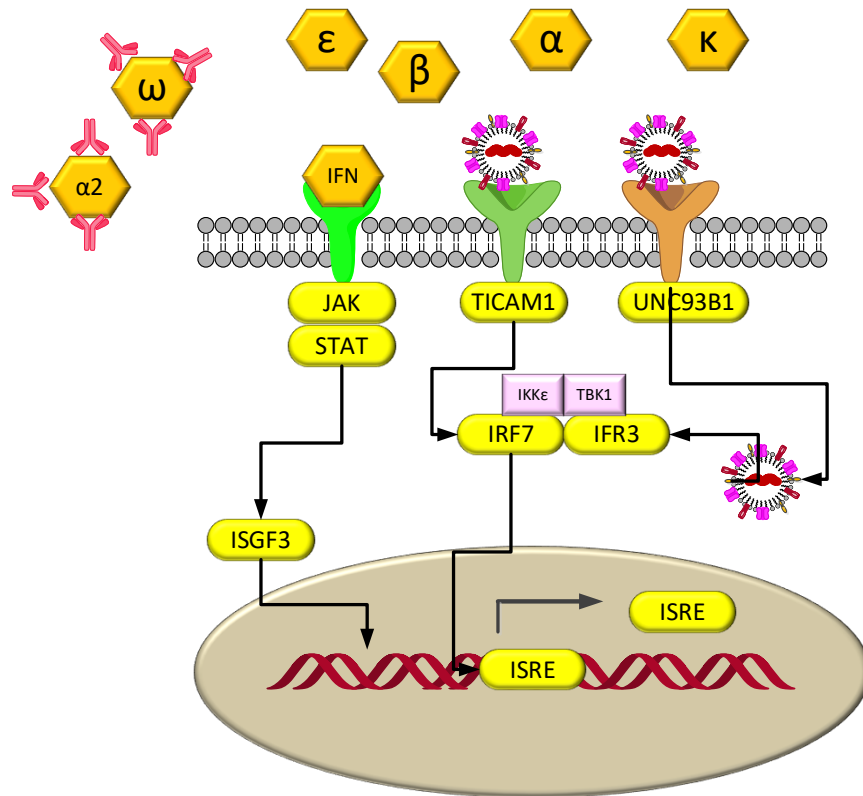

The multiple IFN shown in the above can be blocked by the autoantibodies as shown thus inhibiting the patient's immune response via IFN1 release. As Beck et al note:

By analyzing patients with severe COVID-19, these two studies provide evidence that type I IFNs are protective against COVID-19 and that limiting this response through either gene mutations or autoantibodies leads to severe disease. Autoantibodies against other proinflammatory cytokines— including type II IFN (IFN-g), interleukin-6 (IL-6), IL-17A, and IL-17F—have been reported in healthy individuals, patients with autoimmune diseases, and other opportunistic infections, although the function of these autoantibodies is not always understood. Studying the mechanisms of acquired immunodeficiency, perhaps related to sex and aging, could help reduce infectious disease morbidity and mortality.

Type I IFN concentrations are tightly regulated, with several rare monogenic autoinflammatory and immunodeficiency disorders caused by either too much or too little interferon production, respectively. Healthy people may have impaired type I IFN responses owing to inherited loss-of-function variants in genes encoding components of the type I IFN signaling cascade but remain clinically silent until they encounter particular viruses or other microbes. This may be the case in severe COVID-19 patients who have no prior history of clinical immunodeficiency.

Again there is continued speculation but the above process may be prototypical in how the virus creates autoantibodies against the ameliorating cytokines.

Finally as Bastard et al have noted:

A B-cell autoimmune phenocopy of inborn errors of type I IFN immunity accounts for life-threatening COVID-19 pneumonia in at least 2.6% of women and 12.5% of men. In these patients, adaptive autoimmunity impairs innate and intrinsic antiviral immunity. These findings provide a first explanation for the excess of men among patients with life threatening COVID-19 and the increase in risk with age. They also provide a means of identifying individuals at risk of developing life-threatening COVID-19 and ensuring their enrolment in vaccine trials. Finally, they pave the way for prevention and treatment, including plasmapheresis, plasma blast depletion, and recombinant type I IFNs not targeted by the auto-Abs (e.g., IFN- β)

5.3 HEMATOLOGICAL

Hematological complications are common in COVID-19. As Al-Samkari et al note:

*Patients with coronavirus disease 2019 (COVID-19) have elevated D-dimer levels. Early reports describe high **venous thromboembolism** (VTE) and disseminated intravascular coagulation (DIC) rates, but data are limited. ...Elevated D-dimer at initial presentation was predictive of coagulation-associated complications during hospitalization ...C-reactive protein (CRP) >100 mg/L (adjusted OR, 2.71 [95% CI, 1.26- 5.86]), and erythrocyte sedimentation rate (ESR) >40 mm/h (adjusted OR, 2.64 [95% CI, 1.07-6.51]). ESR, CRP, fibrinogen, ferritin, and procalcitonin were higher in patients with thrombotic complications than in those without. DIC, clinically relevant thrombocytopenia, and reduced fibrinogen were rare and were associated with significant bleeding manifestations. Given the observed bleeding rates, randomized trials*

are needed to determine any potential benefit of intensified anticoagulant prophylaxis in COVID-19 patients.

Chan and Weitz reply to the above noting:

The triggers responsible for COVID-19-associated coagulopathy remain elusive. Potential triggers include cytokine-induced overexpression of tissue factor, endothelial dysfunction with loss of its antithrombotic phenotype, stasis, and hypoxia. This study confirms the correlation between markers of inflammation and coagulation and supports the concept that inflammation is a major driver of the hypercoagulable state.

An inflammation driven hypercoagulable state has also been reported in critically ill patients with viral pneumonia caused by H1N1 or SARS-CoV-1.7 The VTE rate in such patients ranged from 5% to 25%, which is similar to the rates observed in patients with COVID-19. Although intensified anticoagulation regimens may reduce the risk of a thrombotic event, the results of this study raise the possibility that they may increase major bleeding rates to unacceptable levels in critically ill patients. As the world waits for the second wave of COVID-19, randomized trials comparing anticoagulation dosing strategies are urgently needed.

Now Zuo et al have examined these issue in the context of autoantibodies. Namely they note:

*Patients with COVID-19 are at high risk for thrombotic arterial and venous occlusions. Lung histopathology often reveals fibrin-based blockages in the small blood vessels of patients who succumb to the disease. **Antiphospholipid syndrome is an acquired and potentially life-threatening thrombophilia in which patients develop pathogenic autoantibodies targeting phospholipids and phospholipid-binding proteins (aPL antibodies). Case series have recently detected aPL antibodies in patients with COVID-19.***

Here, we measured eight types of aPL antibodies in serum samples from 172 patients hospitalized with COVID-19. These aPL antibodies included anticardiolipin IgG, IgM, and IgA; anti-2 glycoprotein I IgG, IgM, and IgA; and anti-phosphatidylserine/prothrombin (aPS/PT) IgG and IgM. We detected aPS/PT IgG in 24% of serum samples, anticardiolipin IgM in 23% of samples, and aPS/PT IgM in 18% of samples. Antiphospholipid autoantibodies were present in 52% of serum samples using the manufacturer's threshold and in 30% using a more stringent cutoff (≥ 40 ELISA-specific units).

Higher titers of aPL antibodies were associated with neutrophil hyperactivity, including the release of neutrophil extracellular traps (NETs), higher platelet counts, more severe respiratory disease, and lower clinical estimated glomerular filtration rate. Similar to IgG from patients with antiphospholipid syndrome, IgG fractions isolated from patients with COVID-19 promoted NET release from neutrophils isolated from healthy individuals. Furthermore, injection of IgG purified from COVID-19 patient serum into mice accelerated venous thrombosis in two mouse models. These findings suggest that half of patients hospitalized with COVID-19 become at least transiently positive for aPL antibodies and that these autoantibodies are potentially pathogenic

5.4 MYOPATHY

As Dalakas notes:

The inflammatory myopathies constitute a heterogeneous group of acquired myopathies that have in common the presence of endomysial inflammation. Based on steadily evolved clinical, histological and immunopathological features and some autoantibody associations, these disorders can now be classified in five characteristic subsets:

Dermatomyositis (DM) Polymyositis (PM), Necrotizing Autoimmune Myositis (NAM), Anti-synthetase syndrome-overlap myositis (Anti-SS-OM), and Inclusion-Body-Myositis (IBM).

Each inflammatory myopathy subset has distinct immunopathogenesis, prognosis and response to immunotherapies, necessitating the need to correctly identify each subtype from the outset to avoid disease mimics and proceed to early therapy initiation. The review presents the main clinicopathologic characteristics of each subset highlighting the importance of combining expertise in clinical neurological examination with muscle morphology and immunopathology to avoid erroneous diagnoses and therapeutic schemes.

The main autoimmune markers related to autoreactive T cells, B cells, autoantibodies and cytokines are presented and the concomitant myodegenerative features seen in IBM muscles are pointed out. Most importantly, unsettled issues related to a role of autoantibodies and controversies with reference to possible triggering factors related to statins are clarified. The emerging effect SARS-CoV-2 as the cause of hyperCKemia and potentially NAM is addressed and practical guidelines on the best therapeutic approaches and concerns regarding immunotherapies during COVID-19 pandemic....

Inflammatory myopathies (IM) are a heterogeneous group of acquired myopathies that have in common the presence of inflammation in the muscle. Based on distinct clinical, histological, immunopathological and autoantibody features, they have evolved in five distinct subsets: Dermatomyositis (DM), Polymyositis (PM), Necrotizing Autoimmune Myositis (NAM), Anti-synthetase syndrome-overlap myositis (Anti-SS-OM), and Inclusion-Body-Myositis (IBM) 1-6. Each subset has distinct clinical features, pathogenesis, response to therapies and different prognosis requiring careful clinicopathologic correlation with expertise in muscle histopathology for a correct diagnosis and distinction from disease mimics.

5.5 PULMONARY

As Zuniga et al have noted:

The underlying pathophysiology of the novel coronavirus 2019 (COVID-19) has largely been attributed to a hyper-inflammatory response without a clear indication of the underlying mechanism.(1) There has been evidence that autoimmunity may play an important role in the pathogenesis of several conditions associated with COVID-19 such as Guillain-Barre syndrome, autoimmune hemolytic anemia, immune thrombocytopenia purpura, autoimmune encephalitis, and Kawasaki's disease.(2) In addition, recent studies of hospitalized COVID-19 patients have

demonstrated that the majority have positive results to some of the most commonly screened antiphospholipid antibodies.(3) Some COVID-19 patients have also reported persistent symptoms, many of which could be characterized as being rheumatologic in origin...

The goal of this study was to investigate the possibility that COVID-19 patients have autoimmune antibodies to Annexin A2, a critical protective and anti-inflammatory protein expressed in the lung. Annexin A2 has an important role in fibrinolysis, cell membrane stabilization and repair, and maintaining the integrity of the pulmonary microvasculature. Anti-Annexin A2 antibodies are known to be associated with a higher rate of thrombotic events among patients with antiphospholipid disorders.

Given the important protective role of Annexin A2 in the lung, we performed ELISAs on plasma obtained from hospitalized COVID-19 patients to determine whether any antibodies were directed against Annexin A2. For comparison, we also studied antibodies directed against Annexin A5, which is another target of prothrombotic antiphospholipid antibodies, but has not been shown to have a direct role in maintaining the integrity of the pulmonary microvasculature.

Our study finds evidence of higher levels of IgG antibodies directed against Annexin A2 among COVID-19 patients who died. Although the comparisons in anti-Annexin A2 antibody levels as stratified by disease severity were not vastly different in terms of magnitude, the differences between fatal cases and non-critical or critically ill cases were statistically significant. More importantly, anti-Annexin A2 antibody levels strongly predicted mortality after controlling for patient risk factors and for the maximum levels of key laboratory markers associated with severe COVID-19.

We did not identify similar findings for Annexin A5, another target of antiphospholipid antibodies known to be associated with thrombosis. Previously, the pathophysiology of severe COVID-19 had largely been attributed to a cytokine storm, but this hypothesis has been questioned given that the cytokine levels in COVID-19 are not as high as would be expected in severe lung injury. Therefore, the underlying cause of severe COVID-19 still remains to be explained. Several recently published studies have found that autoimmunity may play a key role in the pathophysiology of COVID-19, including the presence of autoantibodies against type I interferons in a subset of critically ill patients.

Another important study demonstrated that a high proportion of hospitalized COVID-19 patients had commonly tested antiphospholipid antibodies detected (i.e., anti-cardiolipin, anti- β 2 glycoprotein, and anti-phosphatidylserine/prothrombin antibodies)

We have previously examined the issue of cytokine storm effect. We argued that it may be more of an innate immune response rather than adaptive. Clearly we may have a combination since the autoantibody response is a matured adaptive response mechanism.

5.6 MULTISYSTEM

As we have noted above, there are multiple system responses involving autoantibodies. Now as Consiglio et al note in what they refer to a multisystem inflammatory syndrome in children, it can be significantly greater. They note:

*Severe acute respiratory syndrome coronavirus 2 (SARS-CoV-2) infection is typically very mild and often asymptomatic in children. A complication is the **rare multisystem inflammatory syndrome in children (MISC) associated with COVID-19**, presenting 4–6 weeks after infection as high fever, organ dysfunction, and strongly elevated markers of inflammation. The pathogenesis is unclear but has overlapping features with Kawasaki disease suggestive of vasculitis and a **likely autoimmune etiology**.*

We apply systems-level analyses of blood immune cells, cytokines, and autoantibodies in healthy children, children with Kawasaki disease enrolled prior to COVID-19, children infected with SARS-CoV-2, and children presenting with MIS-C. We find that the inflammatory response in MIS-C differs from the cytokine storm of severe acute COVID-19, shares several features with Kawasaki disease, but also differs from this condition with respect to T cell subsets, interleukin (IL)-17A, and biomarkers associated with arterial damage. Finally, autoantibody profiling suggests multiple autoantibodies that could be involved in the pathogenesis of MIS-C. ...

The autoantibody profiling presented here revealed a number of possible autoantibody candidates. It is worth noting that the result is not as clear, because the pathogenic autoantibodies seen in well-established autoimmune disorders, such as autoimmune thyroiditis or Addison's disease, or in patients with loss of tolerance due to AIRE deficiency (autoimmune polyendocrine syndrome type-1 [APS1]).

The results here are more diffuse, with many antigens targeted and only a few shared across MIS-C patients as compared to other patient groups. One caveat of these types of arrays is the incorrect structure of some target antigens, and another caveat is the inability of the secondary antibody to detect pathogenic autoantibodies of different classes than IgG, such as IgA. Given that the initial immune response is likely elicited in the respiratory or intestinal mucosa, IgA antibodies are of interest, and IgA antibodies have been directly implicated in Kawasaki disease pathogenesis.

Despite these caveats, there are a number of possible autoantibodies with pathogenic potential detected in the MIS-C patient cohort herein. Overall, the data presented here suggest novel directions for future work toward more mechanistic understanding of the immunopathology in MIS-C, its underlying immune perturbation, and development of better immunomodulatory therapies for mitigating the hyperinflammatory disease and long-term tissue damage in such rare children severely affected by COVID-19.

6 VACCINES AND AUTOIMMUNITY

There is a question regarding the vaccines and their independent impact on autoimmune disease. Namely do vaccines, especially in the case of COVID present an issue regarding the development of autoimmune disorders.

6.1 AUTOIMMUNITY

We have discussed autoantibodies and their relationship to COVID-19 sequella. It is worth looking more broadly at autoimmune disorders in the context of current thinking. From Selmi et al:

Molecular mimicry occurs when foreign antigens share sequences or structural similarities with self-antigens. A classic example of a disease that is involved in molecular mimicry is rheumatic fever, in which T cells respond to a specific peptide epitope of Streptococcus pyogenes and stimulate the generation of the B cells of a cross-reactive antibody to human cardiac myosin, resulting in acute rheumatic fever-associated carditis. Such processes may occur during the pathogenesis of other autoimmune diseases, e.g., Escherichia coli and primary biliary cholangitis (PBC), in which cross-reactivity occurs between E. coli and E2-PDC, triggering the anti-mitochondrial immune response in PBC.6 An additional example is related to reactivity to Campylobacter in the induction of Guillain-Barrè syndrome

We have a significant amount of autoimmune diseases and some of which we can treat. However the challenge is more substantial. They then note:

Post-translational modifications play an important role in autoimmune diseases during pathogenesis.

It is estimated that 50–90% of proteins are subjected to post-translational modifications, and these changes may contribute to tolerance breakdown.

Post-translational modifications include acetylation, lipidation, citrullination, and glycosylation, among others, and are crucial for specific autoantibody recognition of autoimmune diseases, i.e., RA and multiple sclerosis.

Conversely, altered protein degradation that leads to the accumulation and exposure of large amounts of autoantigens may likewise be important. Some pathogens are able to modify self-proteins or expose microbial antigens that resemble self-proteins, thereby creating neoantigens. For example, Porphyromonas gingivalis expresses a peptidylarginine deaminase (PAD) enzyme capable of citrullinating self-proteins (fibrinogen and enolase); these selfproteins act as neoantigens and can bind with high affinity to the major histocompatibility complex class II HLA-DR4 shared epitopes, leading in turn to anti-citrullinated peptide antibodies and rheumatoid arthritis development.

Autoantibodies directed toward modified proteins bind both the native and the modified forms of collagen type II in the pathogenesis of RA; recent data have revealed different B and T cell

epitopes on type II collagen. B and T cell epitopes may undergo citrullination and glycosylation in vivo, thus inducing immune activation in genetically predisposed subjects.

The post translational modifications may very well include a variety of epigenetic changes including methylation and histone coding changes. They then address the innate system as we have been focusing on:

The innate immune system recognizes broad patterns or molecular motifs called pathogen-associated molecular patterns (PAMPs) and damage-associated molecular patterns (DAMPs) by germline-encoded “common” receptors called pattern recognition receptors (PRRs). These mechanisms allow a more rapid screening of self from “non-self” molecules. Toll-like receptors (TLR) are a family of PRRs that recognize PAMPs that are characteristic of pathogenic microorganisms. TLRs play a key role in the interplay between the innate and adaptive immune systems and are associated with the pathogenesis of autoimmune diseases.

By inducing the production of type I interferons (IFNs) and pro-inflammatory cytokines, these sensors are both endosomal and cytosolic, and their activation in dendritic cells (DCs) represents the initiating factor of several autoimmune diseases; in turn, this phenomenon can activate T and B cells and autoantibody production.¹⁰ Interestingly, environmental factors such as viral infections, stress, injury, and UV light are sufficient for exposing endogenous PAMPs to the innate immune system via active/passive release; these PAMP molecules subsequently interact with PRRs such as TLRs to activate NF- κ B-like transcription factors.

We have previously examined the impact of NK cells and also TLR, especially TLRs seen in viral responses.

6.2 VACCINES

One is concerned about the potential of vaccine induced autoimmunity, a sequella infrequently found in many vaccines. As Segal and Shoenfeld have observed the incidence of various autoimmune diseases related to vaccines. They relates some of the historical record worth repeating:

In 1962, Melvin Kaplan released his revolutionary article describing a case of an 11-year-old boy who died of heart failure due to rheumatic fever. Pathology revealed immunoglobulin deposits in the cardiac muscle of the patient, leading Kaplan to explore the role of these antibodies.

He examined the reaction of sera from rabbits immunized with group A streptococcal cells to samples of human heart tissue, conjuring the first established description of what is today a well-accepted paradigm—that structural similarity between bacteria and human protein may lead to the development of cardiac injury in rheumatic fever.

In another canonical article published that same year, Rowley and Jenkin described a novel theory, concerning a possible immune crossreaction between infectious agents and host antigens, causing the development of autoimmunity. These two articles may be viewed as

harbingers to a mass of scientific publications that followed, all exploring the concept of immune crossreactivity due to structural homology between pathogens and self-proteins, a concept commonly termed molecular mimicry.

Molecular mimicry is a term originally referring to the ability of an organism to evade detection by its predator through assuming features of a non-edible object,⁷ yet the concept was expanded to address the significant homology between microbial agents and the human host. Interestingly, the theoretical consequences of such similarities may vary depending on the interpreter.

Molecular mimicry is the critical factor we have been examining herein. A summary of these is presented in the following Table.

<i>Vaccine</i>	<i>Autoimmune disease</i>	<i>Suspected viral element implicated</i>	<i>Suspected homologous human target</i>
H1N1	Narcolepsy	NP	HCRT receptor
	Guillain-Barre syndrome	HA	GM1
HBV	Multiple Sclerosis	SHBsAg HBV polymerase	MOG MBP
HPV	Systemic Lupus erythematosus	HPV LI peptides	NK receptors Complement components
	POTS; postural orthostatic tachycardia syndrome	HPV LI peptides	Cardiac myosin/adrenergic receptors

where the abbreviations are:

- GM1, ganglioside M1;
- HA, hemagglutinin;
- HBV, hepatitis B virus;
- HCRT, hypocretin;
- H1N1, strain of the influenza virus;
- HPV, human papilloma virus;
- MBP myelin binding protein;
- MOG, myelin oligodendrocyte glycoprotein;
- NK, natural killer cells;
- NP, influenza nucleoprotein;
- SHBsAg, small hepatitis B surface antigen;

6.3 PUTATIVE DISORDERS

Following Segal and Shoenfeld, we list and summarize the currently known autoimmune diseases linked to vaccines. They are as follows.

Narcolepsy: *Narcolepsy is a debilitating neurological disorder characterized by uncontrollable rapid eye movement attacks, which are not preceded by a non-rapid eye movement stage as occurs normally. The disease classically manifests as excessive daytime sleepiness, which may be accompanied by disrupted nocturnal sleep, sleep paralysis, hallucinations and obesity. Narcoleptic patients are believed to suffer from selective destruction of hypothalamic neurons,*

which are responsible for producing Orexin, also termed Hypocretin (HCRT), a neurotransmitter involved in regulating sleep-wake states.

Guillain-Barre syndrome: Guillain-Barre syndrome (GBS) is the most common form of acquired flaccid paralysis, believed to result from an autoimmune assault to the peripheral nervous system. Patients commonly present with antibodies for gangliosides, which are important components of peripheral nerve fibers. Various environmental triggers were suggested to be involved in the pathogenesis, among them most notorious is infection with *Campylobacter jejuni*, demonstrated to precede as many as 30% of all reported GBS cases.⁴² Studies have demonstrated molecular similarity between a component of *C. jejuni* and GM1, one of the targets of the autoantibodies found in patients, suggesting a role of molecular mimicry in the pathogenesis of the disease

MS and other demyelinating neuropathies: The first report of neurologic adverse events following HBV vaccines was produced in a postmarketing surveillance issued by the Center for Disease Control (CDC) and the manufacturer. The authors could not detect a conclusive association between any neurologic adverse event and the vaccine. Nevertheless, they relate to their significant limitations in calculating a precise relative risk for the various events reported, due to variations in diagnostic classification of the cases, estimates of the size of the vaccinated population, background incidence of the diseases and the definition of a hypothetical at-risk interval.

Postural orthostatic tachycardia syndrome: Postural orthostatic tachycardia syndrome (POTS) is a heterogeneous disorder of the autonomic nervous system characterized by an inappropriately significant increase in heart rate upon changing from supine to upright position (defined as 30 b.p.m. within 10 min of standing or head-up tilt), accompanied by decreased blood flow to the brain, and leading to orthostatic intolerance.¹⁰⁰ While the exact etiology of the disease is still largely unknown, findings suggest a significant subset of patients suffer from small fiber neuropathy leading to autonomic dysfunction.

Systemic lupus erythematosus: The association between systemic lupus erythematosus (SLE) and HPV infection has been widely demonstrated in several studies. This connection led to the conjecture that the relationship may be one of cause and effect. In two recent publications, Segal et al. raised the hypothesis that HPV may be an environmental trigger eliciting the development of SLE among genetically susceptible individuals. To assess the possible role of molecular mimicry in the relationship between virus and disease, viral peptides were examined for homology to human proteins involved in the pathogenesis of SLE. Significant overlap was found between viral and various potentially SLE-relevant peptides.

This then leads us to examine the need for safer vaccines. It begs the question of what specific antigens are the drivers. For example, we have the mRNA COVID vaccines which are de minimis in putative antigens. One suspects that inactivated viral particles could present a much larger source of such antigens.

7 OBSERVATIONS

We have examined several dimensions of the COVID-19 virus and its mutations. This is an elegantly engineered virus that targets individuals both short term and now as we see in a long term manner. We make several observations and continue to await the understanding of what may be other morbidity and mortality sequella from this virus.

7.1 MUTATIONS

We have examined the threat of multiple mutations. We know that each time the mRNA is replicated one or more nucleotides is mutated. After thousands of mutations and efficient natural selection we have started to see these mutants amongst the infected. They often are faster spreading and possibly more lethal. We see this annually with flu shots. Thus we suspect the need for annual boosters based upon the latest profiles. This then adds dramatically to the base of putative autoantibody drivers.

A second factor is key as well and that is a near real time database of mRNA sequences so that the mutating virus can be better tracked. We have argued elsewhere that this should be an open data set available to any and all with the development of open source tools to assist in the analysis.

7.2 MARKERS

Like ANA, ANCA and other markers we must be able to establish a base of similar profiles which can assist in determining the presence and prevalence of autoantibody driven autoimmune diseases. This may also assist in mitigating against their threat.

7.3 INNATE VS ADAPTIVE

There is a continue tug between the innate and adaptive systems and their impacts on autoimmunity. We have tried to give a balanced view. Although the adaptive is considered the main culprit we believe that a great deal of the innate can and does come into play.

7.4 "MOSAIC OF AUTOIMMUNITY"

Many authors have tried to express the high level of complexity of autoantibodies. For example in a discussion by Freire de Carvalho, the author discusses:

The "mosaic of autoimmunity" describes the multifactorial origin and diversity of expression of autoimmune diseases in humans. The term implies that different combinations of the many factors that are involved in auto-immunity produce varying and unique clinical pictures in a wide spectrum of autoimmune diseases. Most of the factors involved in autoimmunity can be categorized into four groups: genetic, immune defects, hormonal and environmental factors. In this communication, only the environmental factors are reviewed such as: infectious agents (represented by Epstein-Barr virus and cytomegalovirus), vaccines as triggers of autoimmunity,

smoking and its relationship with rheumatoid arthritis, systemic lupus erythematosus, thyroid disease, multiple sclerosis and inflammatory bowel diseases. Some aspects of stress as implicated in causing autoimmunity and the processes leading to autoimmunity are reviewed as well. "Mosaic of autoimmunity" is a term created over a decade ago; it describes the multifactorial origin and diversity of expression of autoimmune diseases.

The term implies that different combinations of factors involved in autoimmunity produce varying and unique clinical pictures that represent a wide spectrum of autoimmune diseases. Most of the factors involved in autoimmunity can be categorized into four groups: genetic, immune defects, hormonal and environmental. Environmental factors have been implicated in autoimmune diseases including infectious agents, vaccines, drugs, smoking, stress, etc.

As we have been noting, the "mosaic" paradigm is much in line with what we have tried to discuss herein. The literature on COVID-19 and autoantibodies and in turn autoimmune disorders is just beginning. We suspect that over the next few years we may very well see a complex set of such challenges. As regards to the vaccine related elements, one can conjecture that the mRNA vaccines may be less prone to such vaccine related issue since all it introduces is the spike protein. Yet time will tell.

8 REFERENCES

1. Abbas et al, Basic Immunology, 4th Ed, Elsevier, 2011
2. Al-Samkari et al, COVID-19 and coagulation: bleeding and thrombotic manifestations of SARS-CoV-2 infection, *Blood*, 23 July 2020, Volume 136, Number 4
3. Bastard and Rosen, Autoantibodies against type I IFNs in patients with life-threatening COVID-19, *Science*, 370:423, 23 October 2020
4. Beck and Aksentijevich, Susceptibility to severe COVID-19, *Science* 23 Oct 2020
5. Bluestone and Anderson, Tolerance in the Age of Immunotherapy, *NEJM*, 17 Sept 2020
6. Chan and Weitz, COVID-19 coagulopathy, thrombosis, and bleeding, *Blood* 23 July 2020 | Volume 136, Number 4
7. Chowdhury et al, Immune response in COVID-19: A review, *Journal of Infection and Public Health* 13 (2020) 1619–1629
8. Consiglio et al, The Immunology of Multisystem Inflammatory Syndrome in Children with COVID-19, *Cell* 183, 968–981, November 12, 2020
9. Dalakas, Inflammatory myopathies: update on diagnosis, pathogenesis and therapies, and COVID-19-related implications, *Acta Myologica* 2020; XXXIX: p. 289-301
10. Ehrenfeld et al, Covid-19 and autoimmunity, *Autoimmunity Reviews* 19 (2020) 102597
11. Elkon and Casali, Nature and functions of autoantibodies, *Nat Clin Pract Rheumatol*. 2008 September; 4(9): 491–498
12. Freire de Carvalho et al, The mosaic of autoimmunity: the role of environmental factors. *Frontiers in Bioscience* E1, 501-509, June 1, 2009
13. Gupta et al, Extrapulmonary manifestations of COVID-19, *Nature Medicine*, 2020
14. Helbert, Immunology, 3rd Ed, Elsevier, 2017
15. Khamsi, Rogue antibodies could be driving severe COVID-19, *Nature*, 19 January 2021
16. Lerma et al, Prevalence of autoantibody responses in acute coronavirus disease 2019 (COVID-19), *Journal of Translational Autoimmunity* 3 (2020)
17. Leslie et al, Autoantibodies as predictors of disease, *Clin. Invest.* 108:1417–1422 (2001)
18. Ludwig et al, Mechanisms of Autoantibody induced Pathology, *Frontiers in Immunology*, May 2017
19. Pascolini et al, COVID-19 and Immunological Dysregulation: Can Autoantibodies be Useful?, *Clin Transl Sci* (2020) 0, 1–7
20. Rajalingam, Human diversity of killer cell immunoglobulin-like receptors and disease, *Kor Jnl Hema*, V 46 No 4 Dec 2011
21. Sacchi et al, SARS-CoV-2 infection as a trigger of autoimmune response, *Clin Transl Sci*. 2021;00:1–10

22. Selmi et al, The long and latent road to autoimmunity, *Cellular & Molecular Immunology* (2018) 15:543 – 546
23. Shoenfeld, *Autoantibodies*, 3rd Ed, Elsevier, 2014
24. Shoenfeld et al, The mosaic of autoimmunity: Prediction, autoantibodies, and therapy in autoimmune diseases – 2008, January 2008 *The Israel Medical Association journal: IMAJ* 10(1):13-9
25. Surmond and Diamond, Autoantibodies in systemic autoimmune diseases: specificity and pathogenicity, *J Clin Invest.* 2015;125(6):2194-2202
26. Uyar, *Structure, Physiology, and Functions of Autoantibodies*, Chapter 2, <https://www.intechopen.com/predownload/61229>
27. Wang et al, Diverse Functional Autoantibodies in Patients with COVID-19, <https://doi.org/10.1101/2020.12.10.20247205> ; this version posted December 19, 2020
28. Zuniga et al, Autoimmunity to the Lung Protective Phospholipid-Binding Protein Annexin A2 Predicts Mortality Among Hospitalized COVID-19 Patients, <https://doi.org/10.1101/2020.12.28.20248807> ; this version posted January 4, 2021
29. Zuo et al, Prothrombotic autoantibodies in serum from patients hospitalized with COVID-19, *Sci. Transl. Med.* 12, eabd3876 (2020) 18 November 2020

9 APPENDIX

In this appendix we present a set of summaries of autoimmune effects.

9.1 MICROBIAL INITIATORS

Microorganism	Related autoimmune diseases
Streptococcus pyogenes	Rheumatoid fever
Escherichia coli	Primary biliary cirrhosis
Shigella spp.	Reiter syndrome
Hepatitis B	Multiple sclerosis
Coxsackie B4	Type 1 diabetes mellitus
Cytomegalovirus	Scleroderma

9.2 SYSTEMIC AUTOIMMUNE DISEASES

Disease	Organ(s) involved	Autoantibodies
Systemic lupus erythematosus	Joints, skin, nervous system, kidneys, blood cells, heart, lungs	Anti dsDNAb Anti Sm b Anti-ribosomal P b Anti RNA helicase
Rheumatoid arthritis	Joints, blood, vessels, lungs	Anti-citrullinated peptides b Rheumatoid factor
Sjogren's syndrome	Exocrine glands (salivary and lacrimal glands), kidneys, nerves	Anti R06O (SS-A) Anti Ro52 Anti La (SS-B)
Scleroderma	Skin, blood vessels, GI tract, lungs, kidneys	Anti-topoisomerase I b Anti-fibrillarin (U3 RNP) b Anti RNA polymerase I b Anti RNA polymerase III b
Polymyositis	Muscles, lungs	tRNA synthetases Histidyl, alanyl, threonyl, glycyl, etc.b Signal recognition particle b

9.3 ORGAN SPECIFIC AUTOIMMUNE DISEASES:

Disease	Organ(s) involved	Autoantibodies
Hashimoto's thyroiditis	Thyroid	Thyroid peroxidase Thyroglobulin
Graves' disease	Thyroid	Thyroid-stimulating hormone receptor
Addison's disease	Adrenal glands	21-hydroxylase
Type I diabetes	Pancreatic islet cells	Glutamic acid dehydrogenase, insulin islet cell antigens
Pemphigus vulgaris	Skin	Desmoglein 3
Bullous pemphigoid	Skin	230 kDa hemidesmosomal antigen
Vitiligo	Skin melanocytes	Unknown melanocyte antigens
Goodpasture's syndrome	Kidneys, lungs	Type VII collagen
Myasthenia gravis	Nervous system	Acetylcholine receptor
Multiple sclerosis	Nervous system	Unknown myelin antigens
Pernicious anemia	Gastric parietal cells	Parietal cell antigens, intrinsic factor
Primary biliary cirrhosis	Bile ducts	Dihydroliipoamide acyltransferase and other antigens b
Autoimmune hepatitis	Liver	Smooth muscle antigens (F-actin)

9.4 ANTIBODY MEDIATED DISEASE:

Disease	Target antigen	Mechanism
Pemphigus vulgaris	Proteins in intercellular junction of epidermal cell	Antibody-mediated activation of proteinase, disruption of intercellular adhesion
Autoimmune hemolytic anemia	Erythrocytes membrane antigen	Opsonization and phagocytosis of erythrocytes
Myasthenia gravis	Acetylcholine receptor	Antibody inhibits acetylcholine binding

9.5 T CELL MEDIATED

Disease	Target antigen	Mechanism
Systemic lupus erythematosus	DNA, nucleoproteins	Complement and Fc region mediated
Polyarteritis nodosa	Hepatitis B surface antigen	Complement and Fc region mediated
Poststreptococcal glomerulonephritis	Streptococcal cell wall antigen	Complement and Fc region mediated

9.6 IMMUNE COMPLEX MEDIATED:

Disease	Target antigen	Mechanism
Rheumatoid arthritis	Antigen in joint synovium	T cell mediated
Type I diabetes mellitus	Islet cell antigen	T cell mediated

9.7 SUMMARIES

<i>Disease</i>	<i>Target Antigen</i>	<i>Mechanisms of Disease</i>	<i>Clinicopathologic Manifestations</i>
<i>Autoimmune hemolytic anemia</i>	Erythrocyte membrane proteins	Opsonization and phagocytosis of erythrocytes, complement-mediated lysis	Hemolysis, anemia
<i>Autoimmune thrombocytopenic purpura</i>	Platelet membrane proteins (gpIIb-IIIa integrin)	Opsonization and phagocytosis of platelets	Bleeding
<i>Pemphigus vulgaris</i>	Proteins in intercellular junctions of epidermal cells (desmoglein)	Antibody-mediated activation of proteases, disruption of intercellular adhesions	Skin blisters (bullae)
<i>Vasculitis caused by ANCA</i>	Neutrophil granule proteins, presumably released from activated neutrophils	Neutrophil degranulation and inflammation	Vasculitis
<i>Goodpasture syndrome</i>	Noncollagenous NC1 protein of basement membrane in glomeruli and lung	Complement- and Fc receptor-mediated inflammation	Nephritis, lung hemorrhage
<i>Acute rheumatic fever</i>	Streptococcal cell wall antigen; antibody cross-reacts with myocardial antigen	Inflammation, macrophage activation	Myocarditis, arthritis
<i>Myasthenia gravis</i>	Acetylcholine receptor	Antibody inhibits acetylcholine binding, down modulates receptors	Muscle weakness, paralysis
<i>Graves' disease (hyperthyroidism)</i>	TSH receptor	Antibody-mediated stimulation of TSH receptors	Hyperthyroidism
<i>Pernicious anemia</i>	Intrinsic factor of gastric parietal cells	Neutralization of intrinsic factor; decreased absorption of vitamin B ₁₂	Abnormal erythropoiesis, anemia, neurologic symptoms

10 INDEX

- Ab, 7, 8, 9, 31
Abs, 8, 35
ADCC, 15
affinity, 10, 11, 14, 15, 16, 17, 21, 22, 40
Ag, 7
ANA, 19, 28, 32, 33, 34
Annexin A2, 38, 47
Anti phospholipid antibodies, 19
antibody, 4, 7, 9, 11, 14, 15, 17, 19, 21, 22, 32, 38, 39, 40, 50
antigens, 9, 14, 15, 16, 17, 18, 19, 22, 29, 30, 31, 32, 34, 39, 40, 41, 43, 49
anti-inflammatory, 23, 38
Antinuclear antibodies, 19
antinuclear cytoplasmic antibodies, 15
antiviral, 34, 35
APCs, 18
APL, 19, 28
apoptotic, 22
autoantibodies, 4, 14, 15, 16, 17, 18, 19, 20, 21, 23, 28, 30, 31, 32, 33, 34, 35, 36, 37, 38, 39, 40, 43, 46, 47
autoantigens, 4, 14, 15, 16, 32, 40
autoimmune, 4, 7, 10, 14, 15, 16, 17, 18, 19, 20, 22, 23, 28, 30, 32, 33, 34, 35, 37, 38, 39, 40, 41, 42, 43, 44, 46, 47, 48
avidity, 11, 21
B cells, 10, 15, 16, 21, 23, 37, 40, 41
CD40, 9
CDC, 24
cells, 24
Class switching, 21
conformation, 26
corona, 24, 25
COVID, 4, 14, 17, 24, 25, 26, 28, 30, 31, 32, 34, 35, 36, 37, 38, 39, 40, 44, 46, 47
COVID-19, 17, 24, 28, 30, 31, 32, 33, 34, 35, 36, 37, 38, 39, 40, 44, 46, 47
cytokine, 4, 17, 19, 29, 30, 36, 38, 39
Dermatomyositis, 37
DIC, 35
disseminated intravascular coagulation, 35
encephalitis, 37
encoding, 25
endoplasmic reticulum, 25
envelope, 25, 26
ERGIC, 25
ER–Golgi intermediate compartment, 25
Genetic abnormalities, 22
genome, 25
Goodpasture syndrome, 50
Graves disease, 15
Graves' disease, 50
Guillain-Barre syndrome, 37, 42, 43
hemolytic anemia, 37, 49, 50
histological, 37
histone, 19, 28, 41
histopathology, 36, 37
HLA, 12, 13, 17, 20, 40
IFN, 29, 31, 34, 35
IgG, 7, 10, 11, 14, 17, 21, 22, 32, 33, 36, 38, 39
immune, 4, 7, 9, 13, 14, 15, 16, 17, 19, 20, 21, 23, 28, 29, 30, 31, 32, 34, 35, 37, 38, 39, 40, 41, 44
immunity, 12, 35, 44
immunization, 4, 24
immunopathological, 37
immunoreactivity, 32
infection, 24
inflammatory, 14, 17, 19, 20, 21, 31, 32, 37, 39, 41, 45
Inflammatory myopathies, 37, 46
interferon, 14, 17, 23, 34, 35
Interferons, 34
intracellular, 25
Kawasaki disease, 39
kidney, 23
Killer cell immunoglobulin-like receptors, 12
KIR, 12, 13, 20
major histocompatibility complex, 10, 40

membrane, 24, 26
MHC, 7, 10, 17
microvasculature, 38
Molecular mimicry, 40, 42
Multiple Sclerosis, 42
mutation, 26
mutational, 4
Myasthenia gravis, 49, 50
Necrotizing Autoimmune Myositis, 37
NK, 7, 8, 12, 13, 19, 20, 41
nucleocapsid, 26
nucleotides, 25, 26
pandemic, 24
pathogenesis, 20, 30, 31, 37, 39, 40, 41, 43, 46
Pemphigus vulgaris, 49, 50
Pernicious anemia, 49, 50
plasma, 32, 35, 38
Polymyositis, 37, 48
proinflammatory, 23, 35
protein, 7, 23, 24, 26, 27, 30, 35, 38, 40, 41, 42, 50
proteins, 25, 26
purpura, 37, 50
replication, 25
RNA, 24, 25
serum, 16, 22, 36, 47
single stranded, 24, 25
Somatic diversity, 22
Somatic hypermutation, 21
spike, 24, 26
spike protein, 25
storms, 4
structural, 25
subgenomic, 25
Systemic Lupus erythematosus, 42
T cell, 7, 18, 23, 39, 40, 49, 50
T-cell, 10
thrombocytopenia, 33, 35, 37
TLR, 17, 34, 41
toll like receptors, 34
Toll-like receptors, 14, 17, 20, 41
transcription, 25
vaccines, 16, 40, 41, 42, 43, 44
VDJ, 9, 21
venous thromboembolism, 35
virions, 8, 26, 27
virus, 24